



HEXAGON

HYDRAULIC AUTOSTEERING Installation Manual



23 May 2022

Introduction

This manual contains important information on how to install the hydraulic Autosteering system.

- Carefully read this User's Manual before connecting the equipment;
- To ensure your safety, please observe the instructions contained in this manual and the agricultural machinery manual.

The symbols used in this manual have the following meanings:

Type	Description
 DANGER	Indicates an imminently hazardous situation, which, if not avoided, will result in death or serious injury.
 WARNING	Indicates a potential hazard or misuse situation, which, if not avoided, may result in minor or moderate injury, material or financial loss and environmental damage, or all of them.
 IMPORTANT	Important information that should be observed, so that the equipment can be used in a technically correct and efficient way.

Contents

1	Safety Information	5
2	Installation Overview	6
2.1	General Diagram	6
2.1.1	Ti10 Diagram.....	6
2.1.2	Ti7 Diagram.....	7
2.2	Preparing the Vehicle for Installation.....	8
2.3	Recommended Tools.....	8
3	Hydraulic System Installation	9
3.1	Identification of the Type of Direction.....	9
3.2	Hydraulic Diagram	11
3.2.1	Non-reactive Open Center Steering (ON)	11
3.2.2	Non-reactive Open Center Steering (ON) – Method 2	11
3.2.3	Reactive Open Center Steering (OR) or with Priority Valve.....	12
3.2.4	Closed Center Steering with Static Load Sense (SLS)	12
3.2.5	Closed Center Steering with Dynamic Load Sense (DLS).....	13
3.2.6	Closed Center Steering with Dynamic Load Sense (DLS) – Method 2	13
3.3	Valves Installation.....	14
3.3.1	Valve with Dynamic LS and Pressure Sensor (01707)	14
3.3.2	Valve with Static LS and Pressure Sensor (01708)	15
3.3.3	Dual Motion Control Valve (MCP) Holding (01709).....	16
3.3.4	Valve without LS (Open Center) with Pressure Sensor (01710)	16
3.4	Installation of Hydraulic Hoses	17
3.4.1	Non-reactive Open Center Steering (ON)	19
3.4.2	Non-reactive Open Center Steering (ON) – Method 2	20
3.4.3	Reactive Open Center Steering (OR) or with Priority Valve.....	21
3.4.4	Closed Center Steering with Static Load Sense (SLS)	22
3.4.5	Closed Center Steering with Dynamic Load Sense (DLS).....	23
3.4.6	Closed Center Steering with Dynamic Load Sense (DLS) – Method 2	24
4	Steering Angle Sensor	25
4.1	Mechanical Installation of the Steering Angle Sensor.....	25
5	Electric System Installation.....	28



5.1	Installing the ECU (Driver)	28
5.2	Harness List	29
5.3	ECU (Driver) Pinout	30
6	Settings	31
6.1	Initial Settings	31
6.1.1	Support Mode	31
6.1.2	Checking Activations	32
6.1.3	Vehicle Configuration	33
6.2	Auto Steering Settings Menu	34
6.3	Support Mode	35
6.4	Tests	36
6.4.1	Wheel Sensor Installation	36
6.4.2	Hydraulic Installation	37
6.4.2.1	Dead Band Test	38
6.4.2.2	VH Control Test	38
6.4.3	INS Install	39
6.5	Calibration	41
6.5.1	Driver Position	41
6.5.2	Accelerometer Calibration	43
6.5.3	Gyroscope Calibration	44
6.5.4	Steering Reading Calibration	44
6.5.5	Clockwise and Counterclockwise Calibration	45
6.6	General Configuration Hydraulic Autopilot	46
6.7	Control Adjustments	47
6.7.1	Overshoot	48
6.7.2	Aggressiveness	49
6.7.3	Sensibility	49
6.7.4	Speed Gain (%)	50
6.7.5	Curve Aggressiveness	50
6.7.6	Techniques and Recommendations for Adjustments	51
6.8	Operation	52
7	Problems and Solutions	53

1 Safety Information

The following instructions intend to inform users, about the risks inherent to the installation of the Autopilot and how to avoid them.



The following personal protective equipment are mandatory during the installation:

- Gloves for handling sharp or abrasive materials;
- Protective glasses for handling contents or systems under hydraulic pressure;
- Boots to work in wet locations ditches and swamps or when in contact with chemicals



Whenever the vehicle is in operation, parts of the vehicle, including the engine and exhaust systems may be extremely hot and can cause serious burns. To avoid burns, wait for these hot parts to cool down before starting to work with them



Avoid wearing loose clothing and/or chains around the equipment containing movable, loose or irregular parts as they can hold and cause injuries.



The Remove the ignition key and place a protective plate “Do not operate” in the cabin when you are working in order to avoid serious or fatal injury



The Agricultural machinery may have been exposed to many types of chemicals. Any chemical or waste, must be removed from the agricultural vehicle before starting any work:

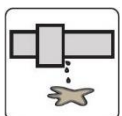

The Use extreme caution when working with pressurized systems (air, water, oil). Release all the system pressure before disconnecting any fixture. Use a cloth, or other obstruction to divert possible leakage. Always wear gloves, NEVER use your bare hands. To find or check for leaks use a cardboard



The installation process may put you in contact with hazardous substances, like oils, which may cause poisoning. Thoroughly wash your hands after you finish working:



DANGER

Unauthorized modification of the vehicle for assembly or installation of the product may alter the function and safety of agricultural machinery:



DANGER

Battery terminals and related accessories may contain lead, which can cause serious illnesses. To avoid lead ingestion, wash your hands immediately after any contact with the battery:

2 Installation Overview

⚠ WARNING

The Hydraulic Autopilot is intended solely for agricultural use, in an open field with agricultural vehicles approved by the manufacturer for hydraulic autopilot use. It cannot be used under any other circumstances, with any other type of vehicle, or for any other purpose.

2.1 General Diagram

The autopilot structure is composed of a monitor, an ECU (driver), harness and actuators. A general diagram is shown in the following picture, where you can view how the elements are interconnected.

2.1.1 Ti10 Diagram

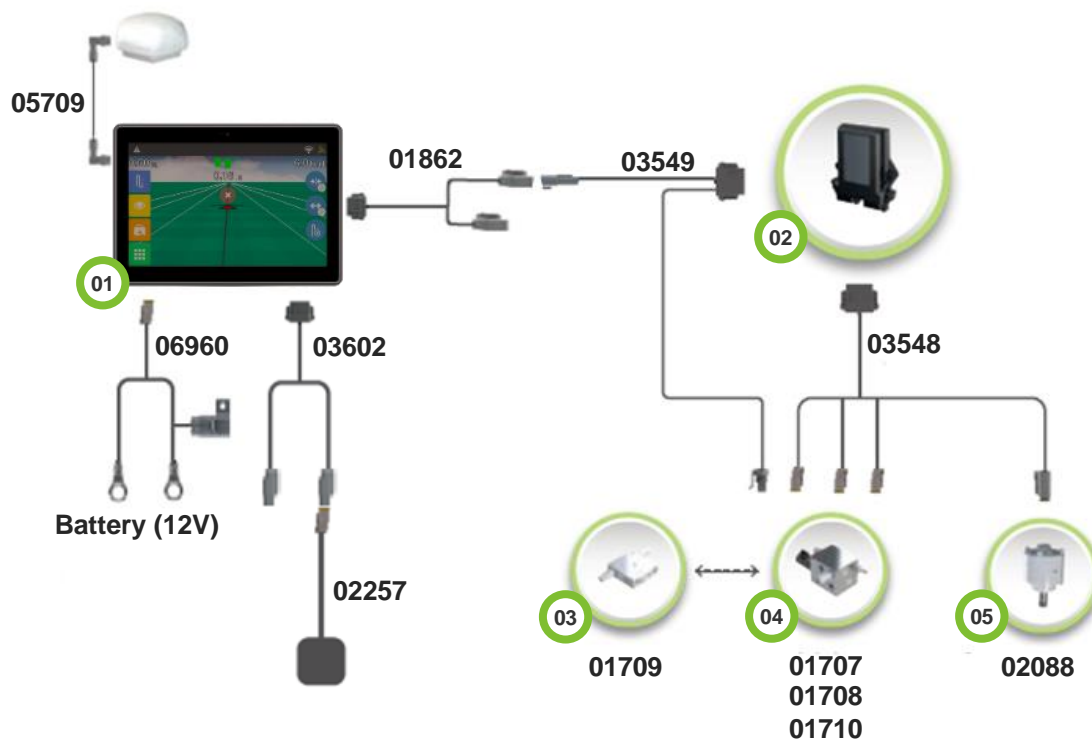



Identification	Code	Description
1		Ti10 with autopilot activation
2	04140	ECU (driver) Hydraulic Autopilot
3	01709	Dual Motion Control (MCP) Holding valve
4	01707	5V valve with dynamic LS and pressure sensor
	01708	5V valve with static LS and Pressure Sensor
	01710	4V valve without LS and with Pressure Sensor
5	02088	Angle sensor

2.1.2 Ti7 Diagram

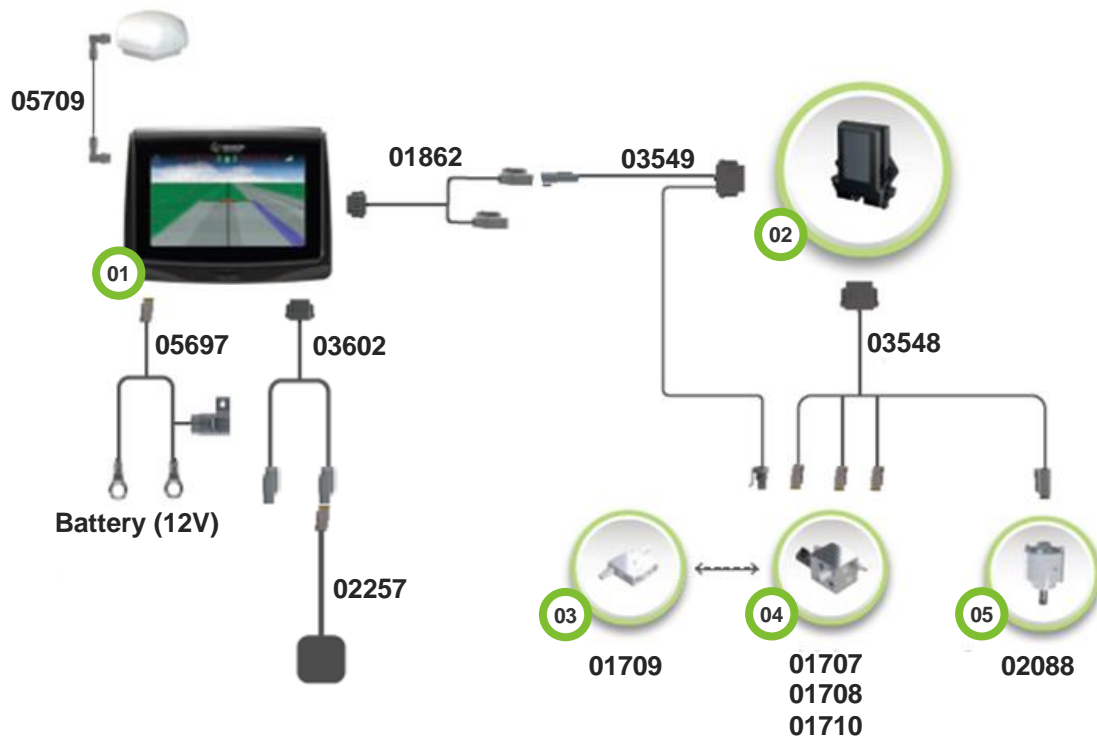



Identification	Code	Description
1		Ti7 with autopilot activation
2	04140	ECU (driver) Hydraulic Autopilot
3	01709	Dual Motion Control (MCP) Holding valve
4	01707	5V valve with dynamic LS and pressure sensor
	01708	5V valve with static LS and Pressure Sensor
	01710	4V valve without LS and with Pressure Sensor
5	02088	Angle sensor

2.2 Preparing the Vehicle for Installation

- Park the vehicle on a hard and flat surface;
- Engage the parking brake and remove the key from ignition;
- In an articulated vehicle install the hinge locks;
- Remove dirt from areas where the system is installed;
- Open the boxes of the kits in a clean place;
- Check the items in the box with the materials list.

2.3 Recommended Tools

- Drilling machine;
- Drill bit 6,5/8,5/13 (mm).
- Socket wrenches 3/10/11/13/14/15/17/19/22/24/27 (mm);
- Hexagonal wrenches (Allen) 2/2,5/3/4/5/6/8 (mm);
- Cutting pliers;
- Needle nose pliers;
- Phillips screwdriver 3/5/8 (mm);
- Screwdriver 3/5/8 (mm);
- Zip ties.

3 Hydraulic System Installation

Before installing the hydraulic system, follow the guidelines below:

i **IMPORTANT**

- If available, check the indicative label.
 - Mark the hoses before disassembling the original system.
 - Check the origin/destination of the hoses to certify the function of each one.
 - Assess whether hose gauges make sense, for example, Pressure and Tank will hardly be thinner than Left and Right.
-

3.1 Identification of the Type of Direction

1. Check the indicative label for information on your tractor's steering orbital connections.

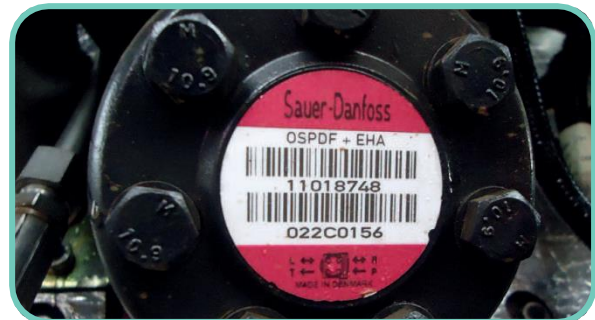
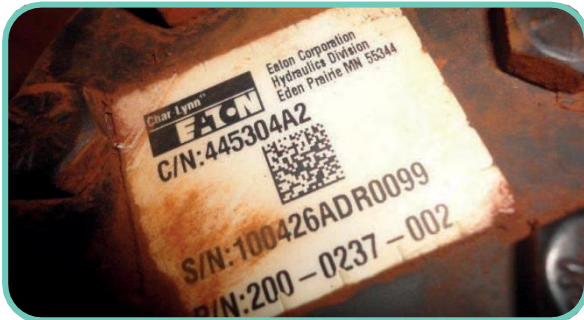

2. Identify the steering orbital model and check the corresponding hydraulic diagram.

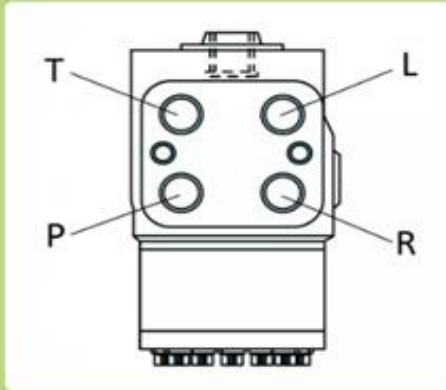
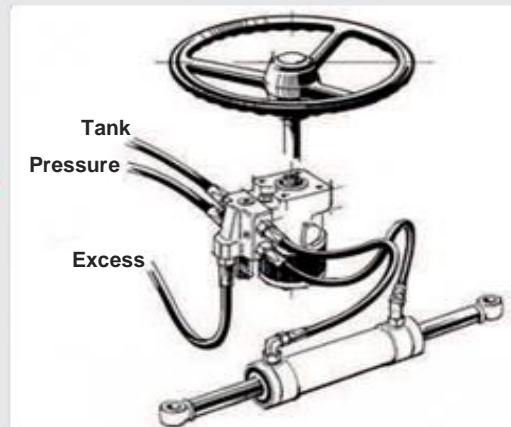
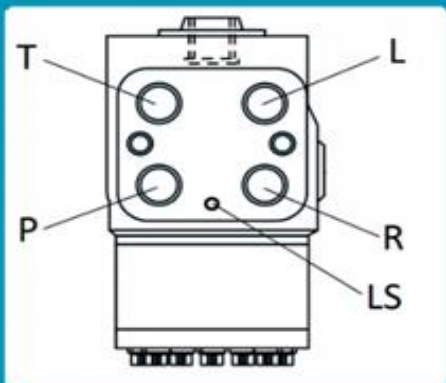
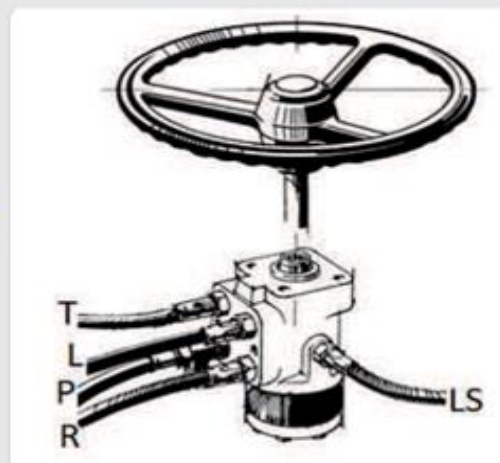
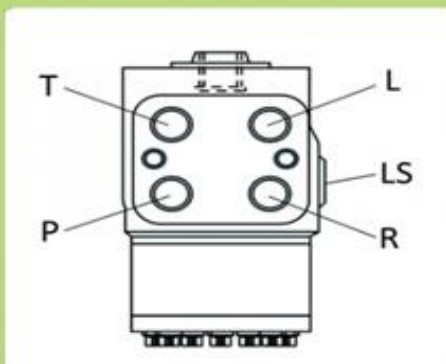
Steering orbital connections – non-reactive open center

Steering orbital connections – reactive open center (OR) or with priority valve

Steering orbital connections – closed center

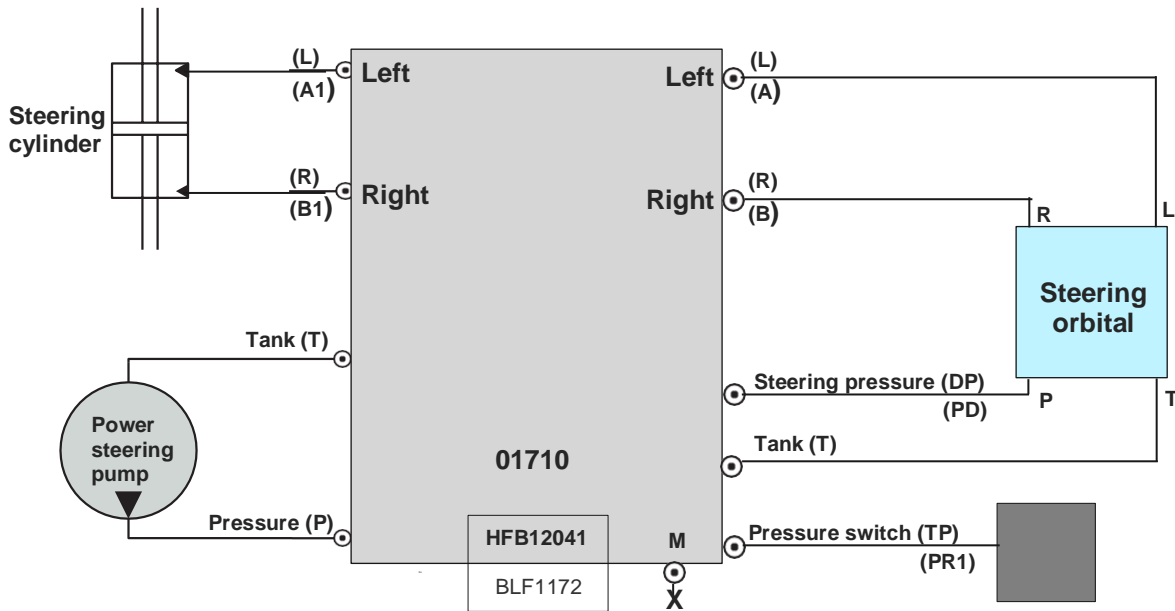
3.2 Hydraulic Diagram

3.2.1 Non-reactive Open Center Steering (ON)

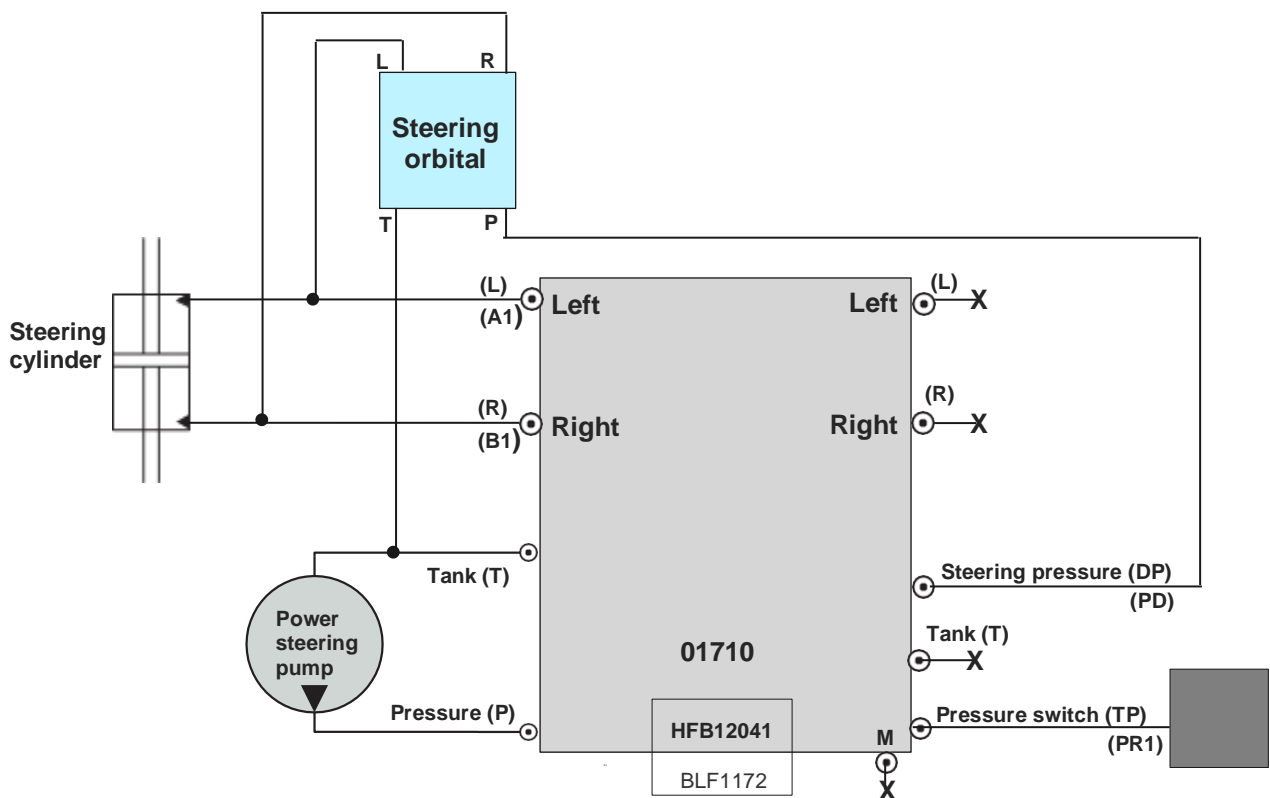

3.2.2 Non-reactive Open Center Steering (ON) – Method 2



3.2.3 Reactive Open Center Steering (OR) or with Priority Valve

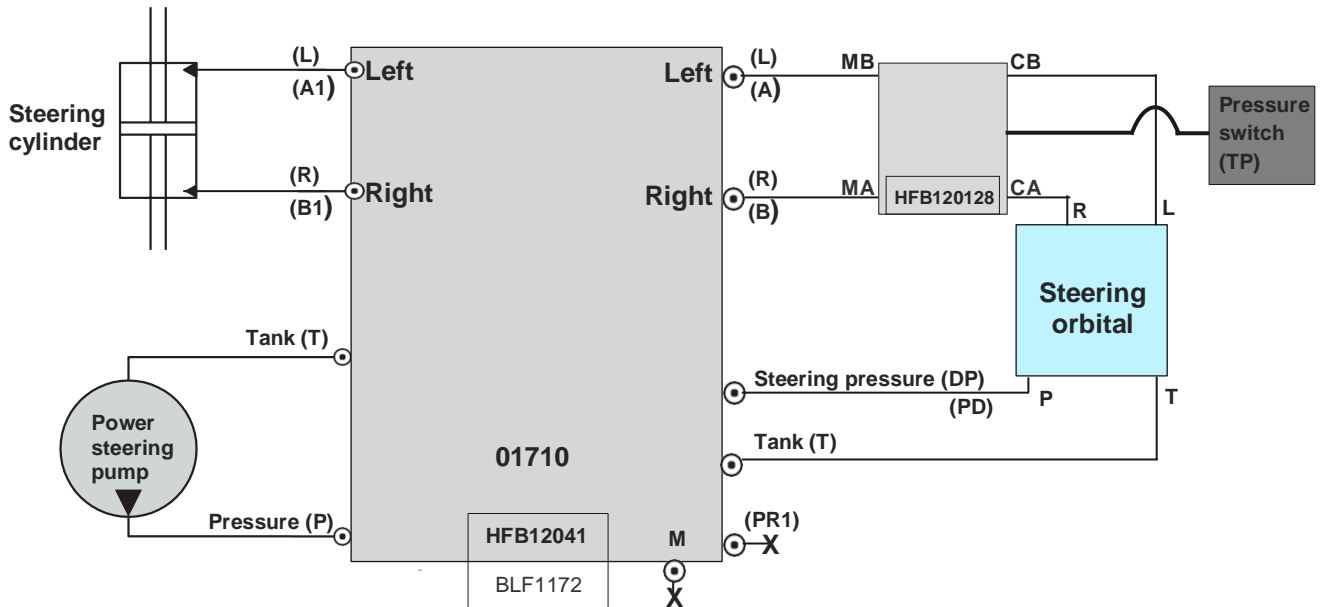

3.2.4 Closed Center Steering with Static Load Sense (SLS)

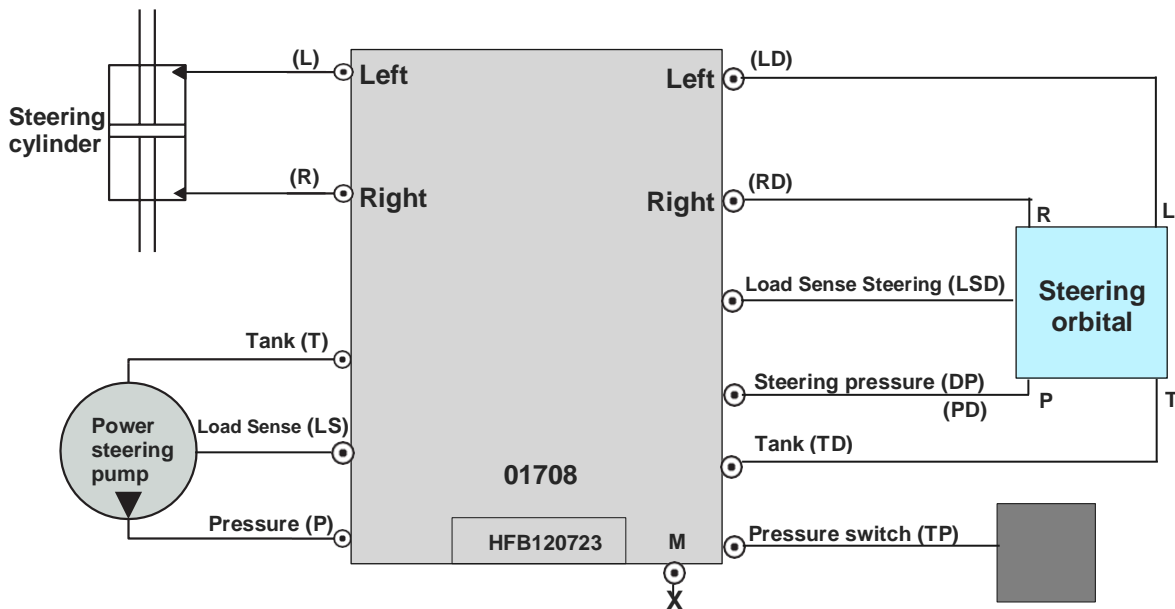

3.2.5 Closed Center Steering with Dynamic Load Sense (DLS)

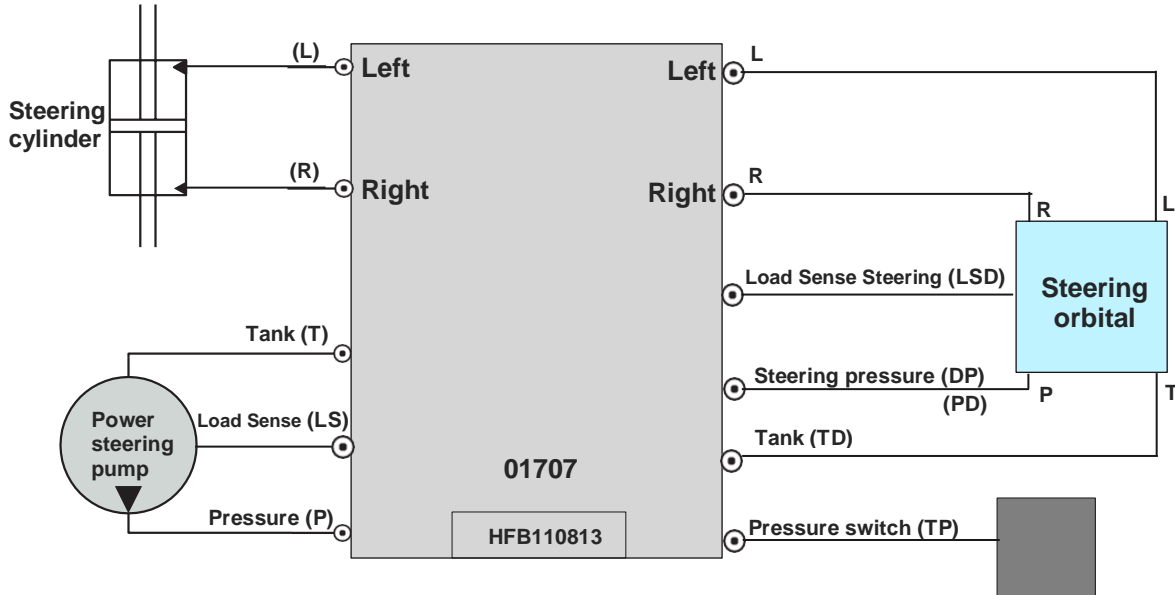

3.2.6 Closed Center Steering with Dynamic Load Sense (DLS) – Method 2

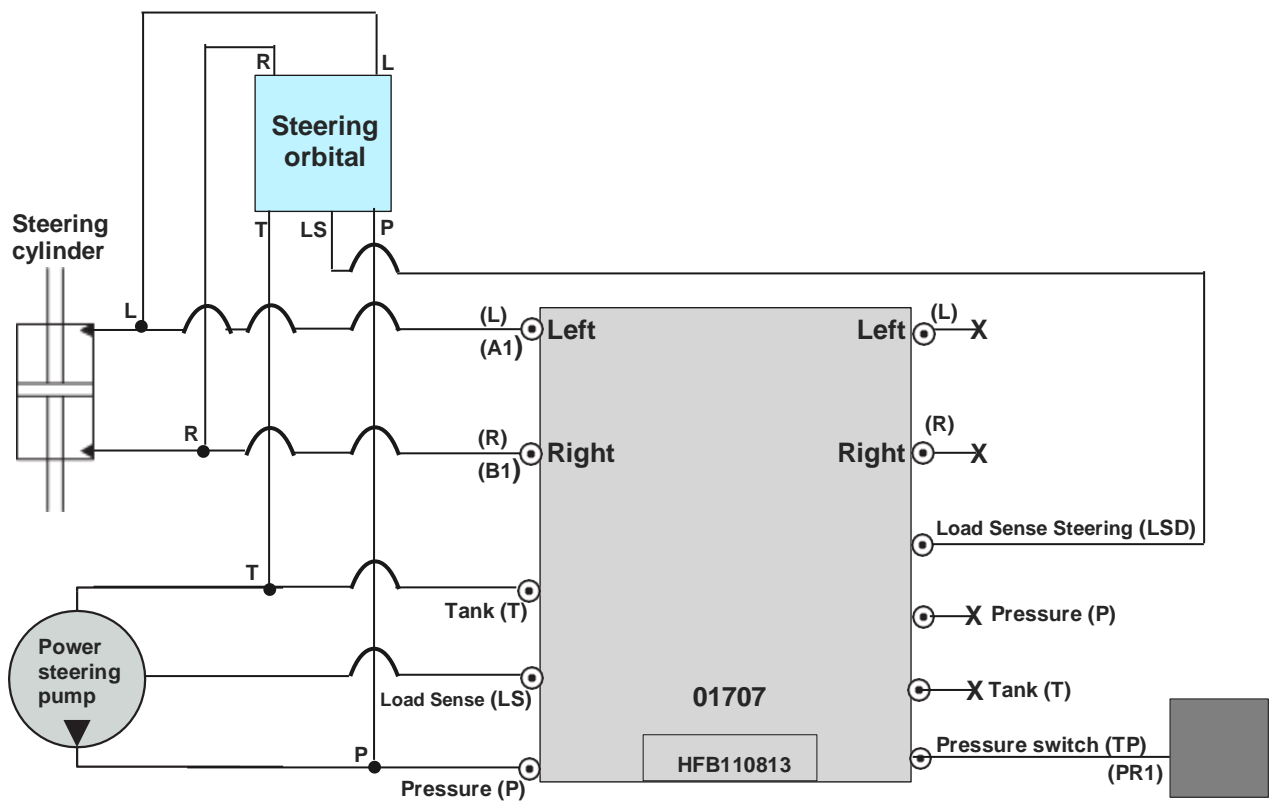

3.3 Valves Installation

Check the valve that makes up the autopilot installation structure and follow the installation instructions below:

3.3.1 Valve with Dynamic LS and Pressure Sensor (01707)

Step 1:

Identify an appropriate mounting location. Recommended mounting dimensions are: **100mm (H) X 105mm (W) X 230mm (D)**. Drill the support holes as indicated in the image beside, at an appropriate location, on the tractor. Use the stand as a template.

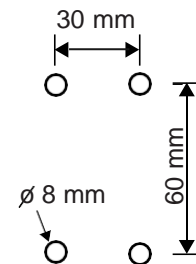
**! WARNING**

Be sure to check the inside or bottom of the structure before drilling to avoid drilling into hydraulic pipes and electrical wires.

Step 2:

Fasten the valve to the support with bolts (M8X12mm).

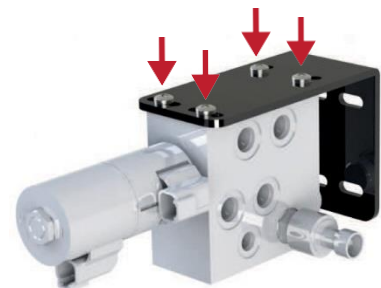
**Step 3:**

Fasten the support with the valve to the tractor, using four bolts (M8X40mm).

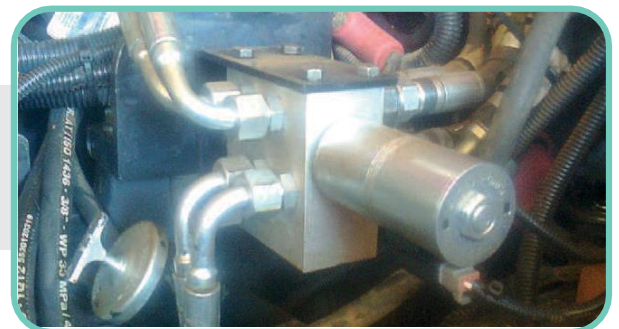

3.3.2 Valve with Static LS and Pressure Sensor (01708)

Step 1:

Identify an appropriate mounting location. Recommended mounting dimensions are:

110mm (H) X 115mm (W) X 245mm (D). Drill the support holes as indicated in the image beside, at an appropriate location on the tractor. Use the stand as a template.

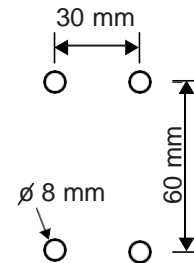
 **WARNING**

Be sure to check the inside or bottom of the structure before drilling to avoid drilling into hydraulic pipes and electrical wires.

Step 2:

Fasten the valve to the support with bolts (**M8X12mm**).

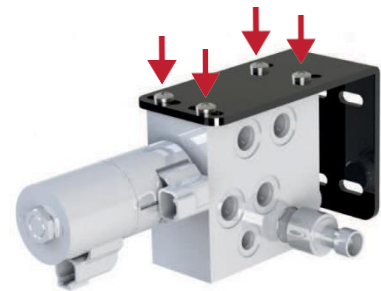
Step 3:

Fasten the support with the valve to the tractor, using four bolts (**M8X40mm**).

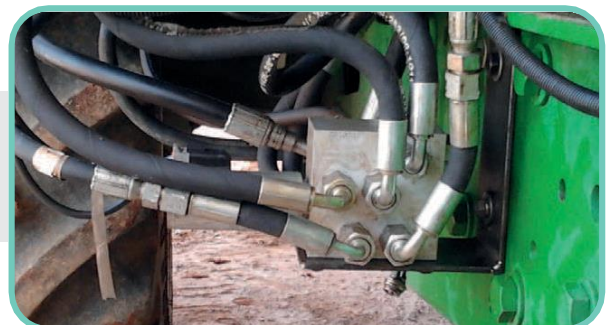

3.3.3 Dual Motion Control Valve (MCP) Holding (01709)

⚠ WARNING

Check for a proper valve installation location. This must be installed directly on the tractor structure. If this is not possible, make a bracket.

Step 1:

Identify an appropriate mounting location. Recommended mounting dimensions are: **140mm (H) X 250mm (W) X 40mm (D)**. Drill the holes as indicated in the image beside.

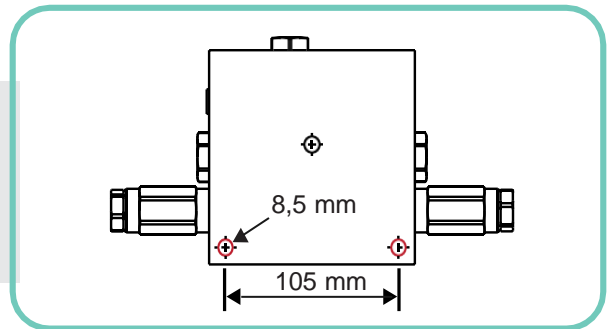

⚠ WARNING

Be sure to check the inside or bottom of the structure before drilling to avoid drilling into hydraulic pipes and electrical wires.

Step 2:

Fasten the valve on the tractor with bolts (**M8X12mm**).



3.3.4 Valve without LS (Open Center) with Pressure Sensor (01710)

Step 1:

Identify an appropriate mounting location. Recommended mounting dimensions are: **170mm (H) X 300mm (W) X 110mm (D)**. Drill the support holes as indicated in the image beside, at an appropriate location on the tractor. Use the stand as a template.

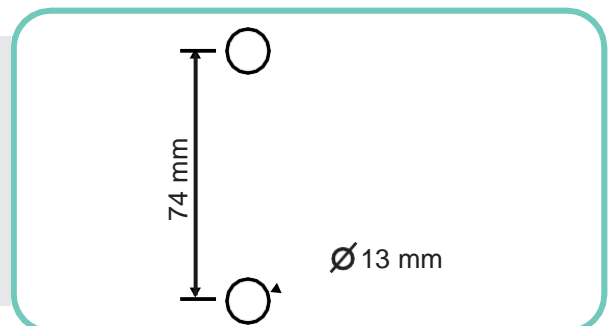

⚠ WARNING

Be sure to check the inside or bottom of the structure before drilling to avoid drilling into hydraulic pipes and electrical wires.

Step 2:

Fasten the valve on the tractor with bolts (**M8X12mm**).
Check the best way to position it on the tractor to fasten the valve in the correct position.

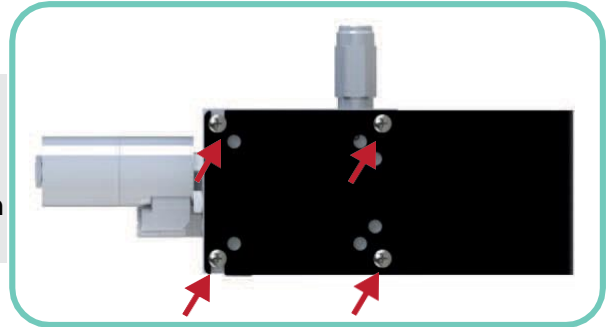
**Step 3:**

Fasten the support with the valve to the tractor using bolts (**M12X40mm**).

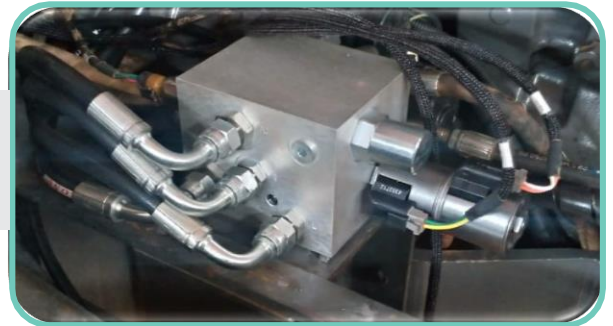

3.4 Installation of Hydraulic Hoses

This kit does not come with hydraulic hoses. Make sure that when making new hoses, contaminants are not introduced into the vehicle's hydraulic system.

Before assembly, a careful examination of the hose and equipment must be carried out.

The hose should be examined for possible obstructions, bubbles, kinks, cracks, cuts or any other visible defects. Inspect mounting and sealing surfaces for burrs, corrosion or other imperfections. Do not use any components with signs of non-compliance. For proper operation, hoses must be of correct length, as hoses that are too short can cause a weak flow transmission and will shorten the hose life.

Avoid kinks in the assembly when mounted in places where the hose moves.

The hose shall be mounted with a certain clearance to avoid contact with parts that may cause damage or abrasion.

Use appropriate connections to avoid bottlenecks. The curvature should not start at less than 1.5 times the size of the connection.

For hose installation, check the connection diagrams in the following sections.

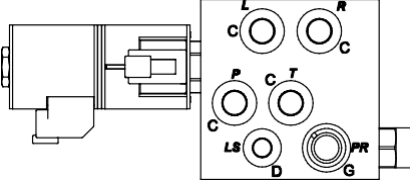
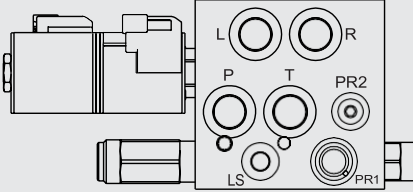
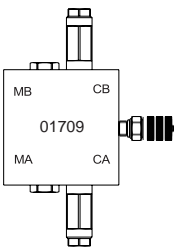
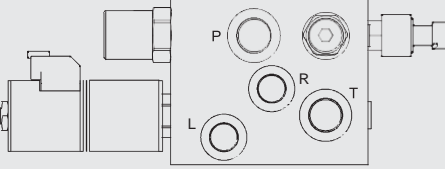
Code	Valve	Thread Type
01707		LSD P = UNF 06 - 9/16" T = UNF 06 - 9/16" L = UNF 06 - 9/16" R = UNF 06 - 9/16" LS = UNF 04 - 7/16"
01708		LSE P = UNF 08 - 3/4" T = UNF 08 - 3/4" L = UNF 08 - 3/4" R = UNF 08 - 3/4" LS = UNF 04 - 7/16"
01709		Holding CA = UNF 08 - 3/4" CB = UNF 08 - 3/4" MA = UNF 08 - 3/4" MB = UNF 08 - 3/4" FR = M12x1,25
01710		CA - Hydraulic Designers CA - Fluid Power P = UNF 10 - 7/8" P = UNF 08 - 3/4" T = UNF 10 - 7/8" T = UNF 08 - 3/4" L = UNF 08 - 3/4" L = UNF 08 - 3/4" R = UNF 08 - 3/4" R = UNF 08 - 3/4"

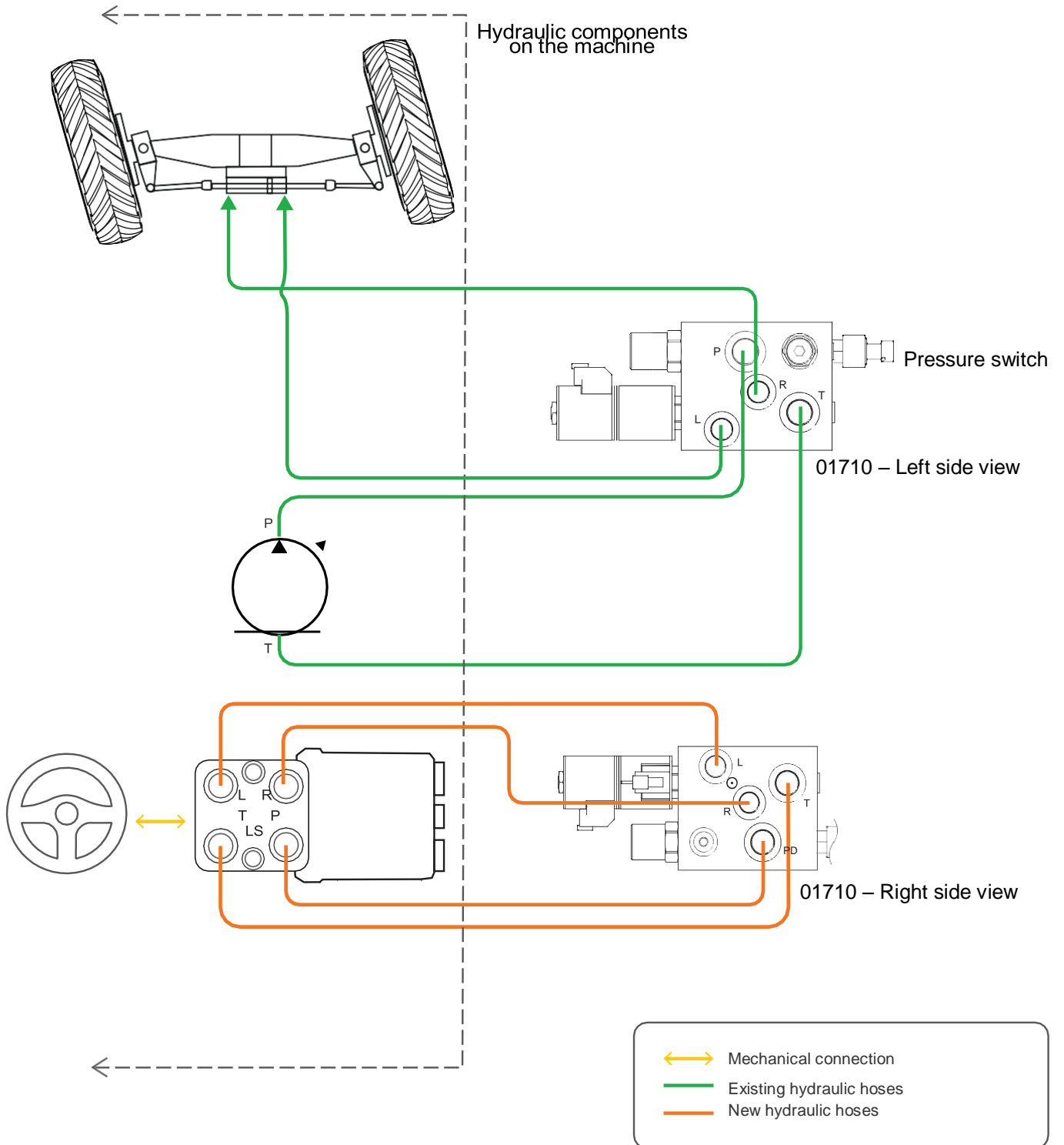
3.4.1 Non-reactive Open Center Steering (ON)

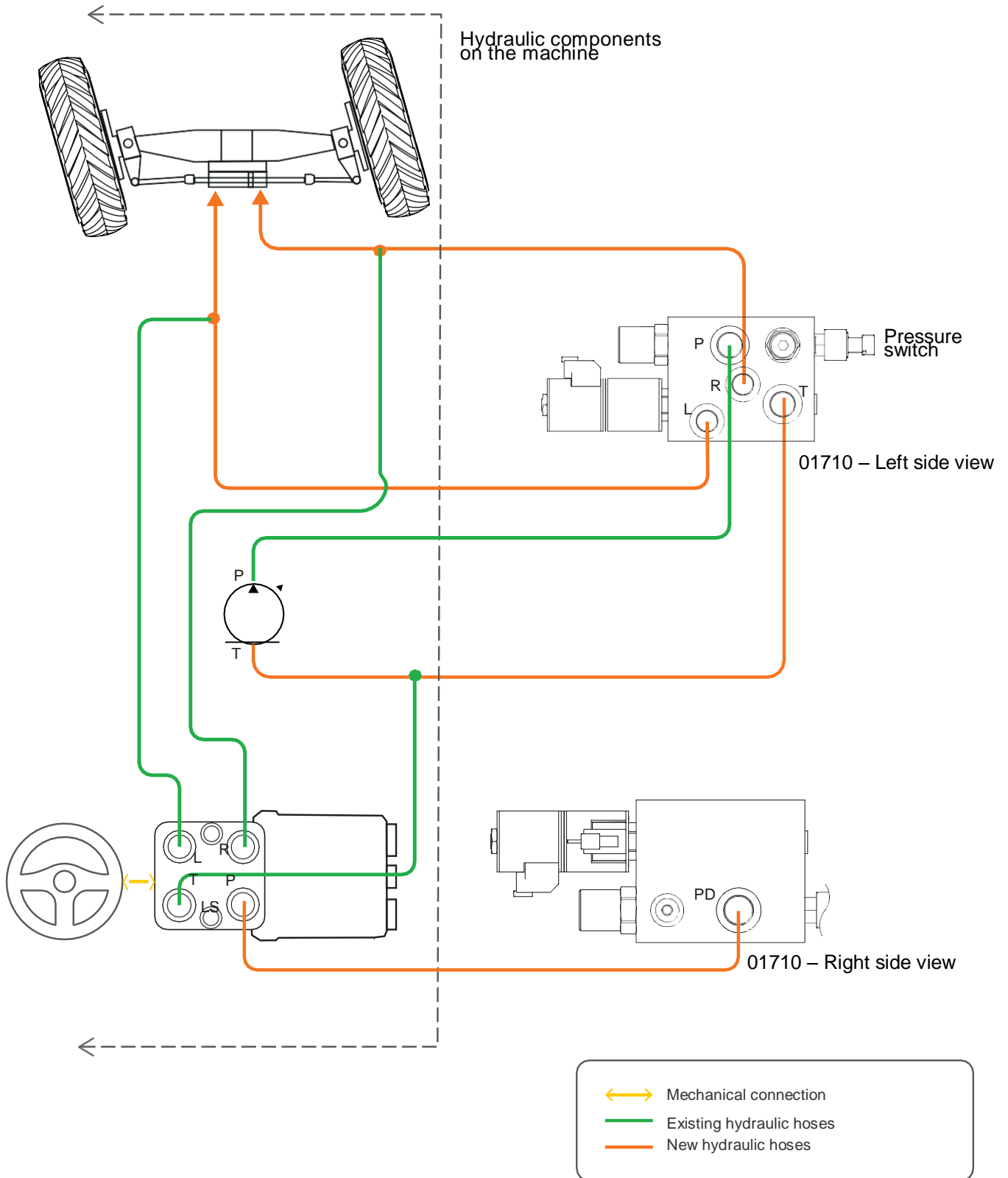
3.4.2 Non-reactive Open Center Steering (ON) – Method 2

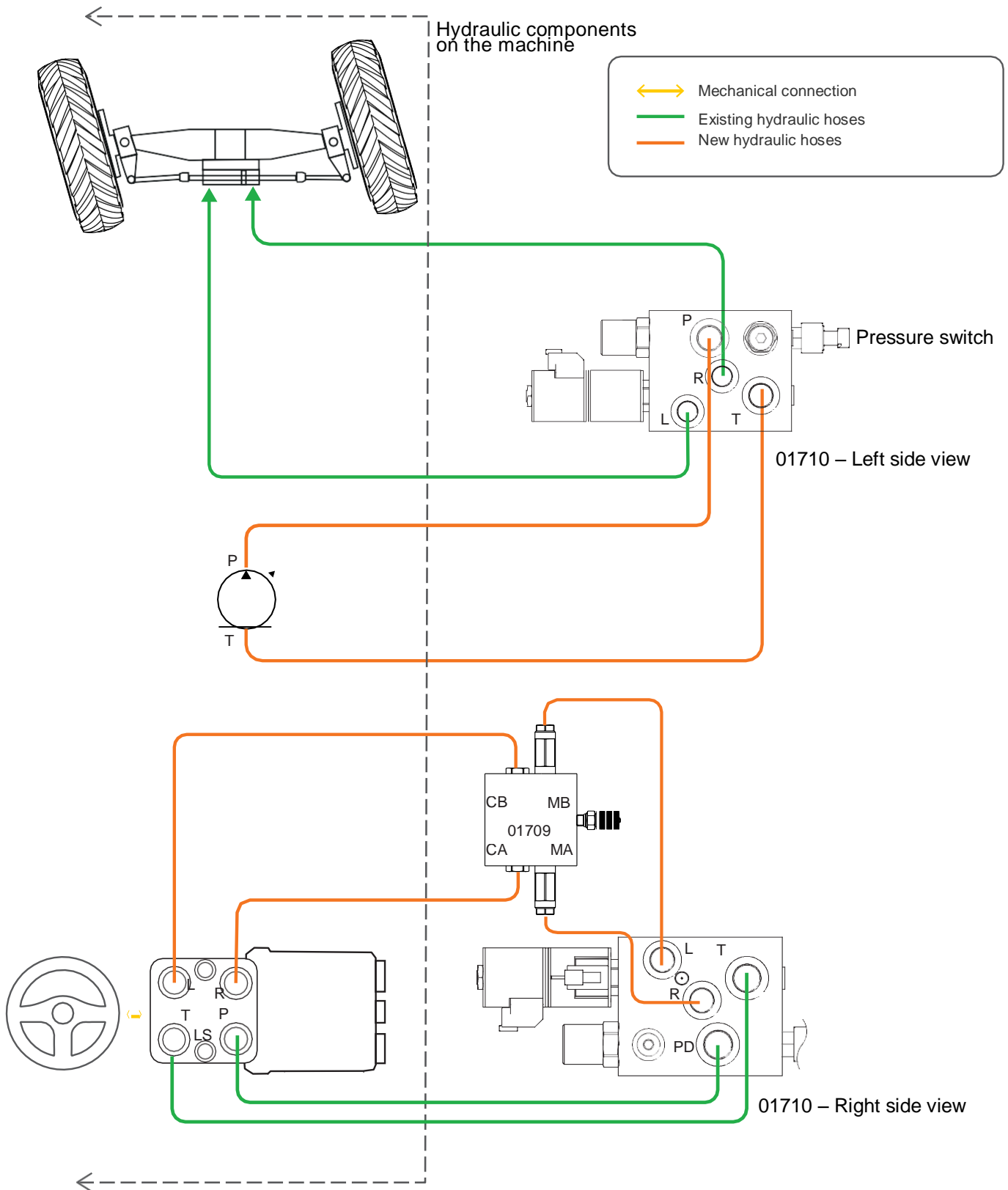
3.4.3 Reactive Open Center Steering (OR) or with Priority Valve

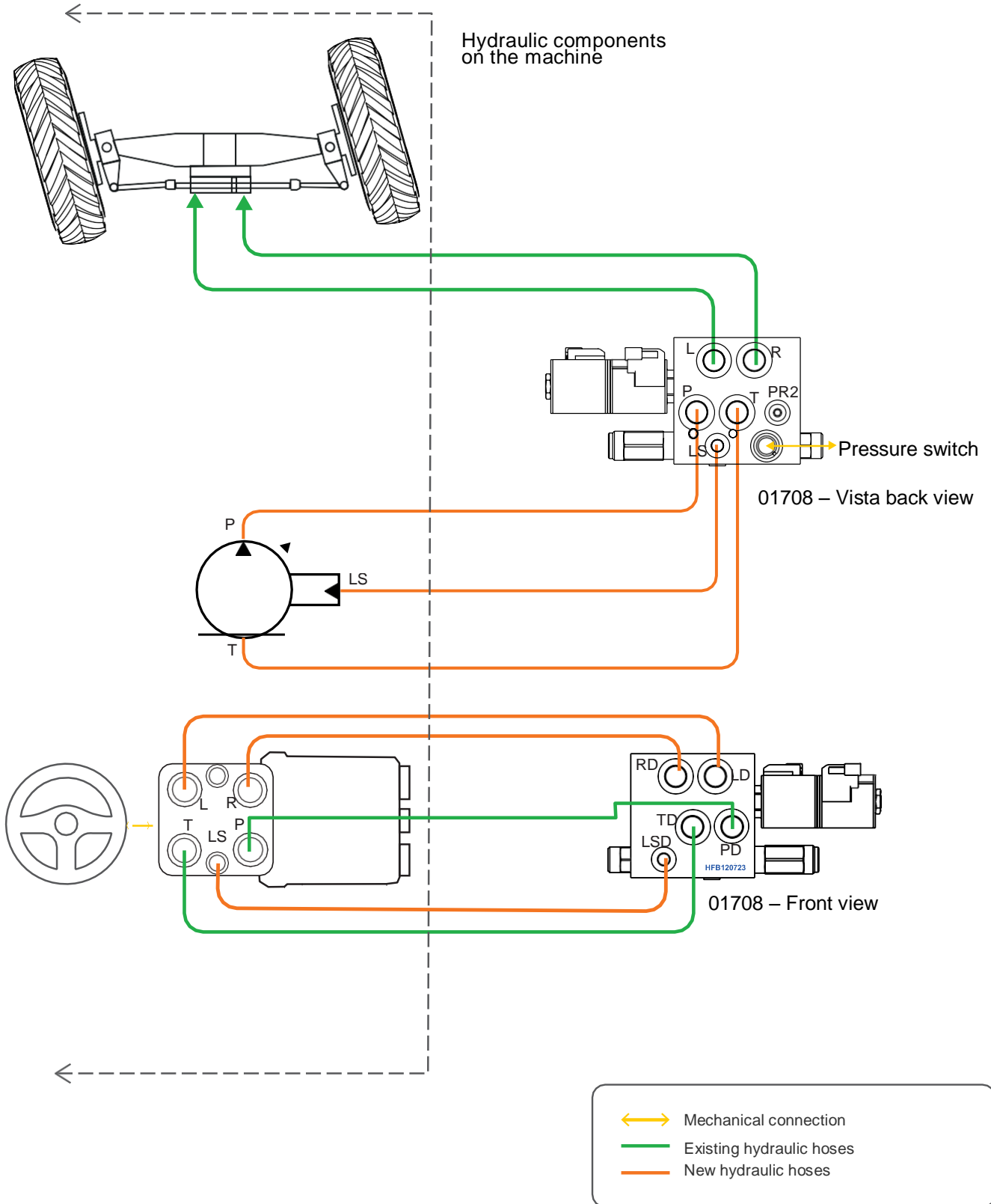
3.4.4 Closed Center Steering with Static Load Sense (SLS)

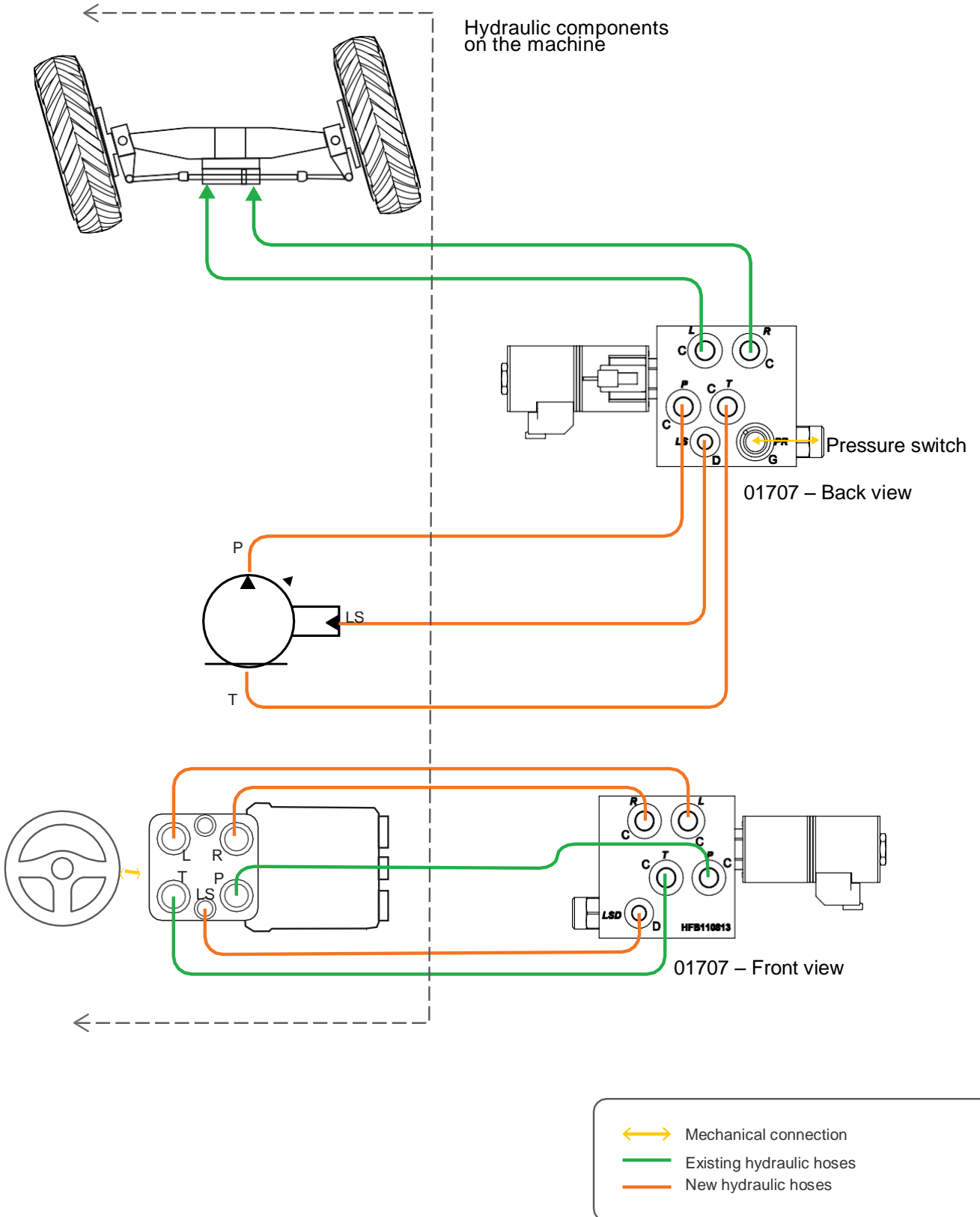
3.4.5 Closed Center Steering with Dynamic Load Sense (DLS)

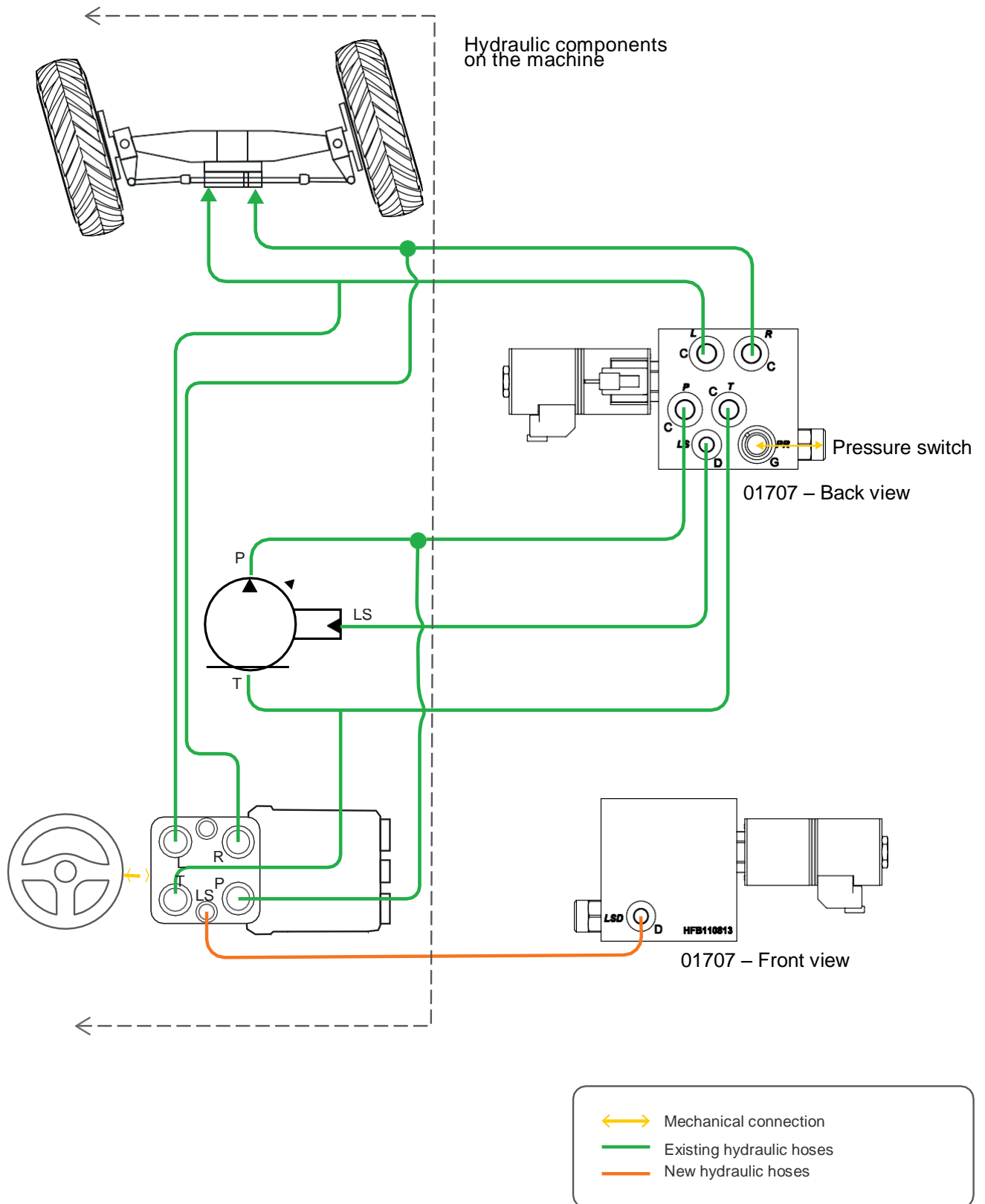
3.4.6 Closed Center Steering with Dynamic Load Sense (DLS) – Method 2

4 Steering Angle Sensor

4.1 Mechanical Installation of the Steering Angle Sensor

Step 1:

Drill the sensor support hole in an appropriate place (02329).

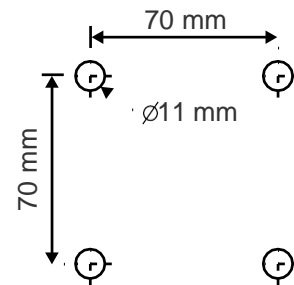
Step 2:

Attach the sensor to the support using screws (M6X30mm).

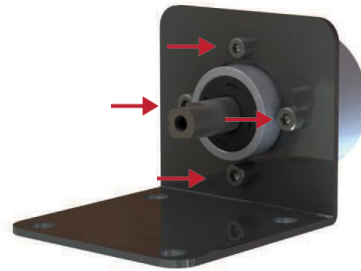
Step 3:

Attach the sensor arm (01101) on the sensor using the M8 bolt that comes in the (01230) kit and the safety pin.

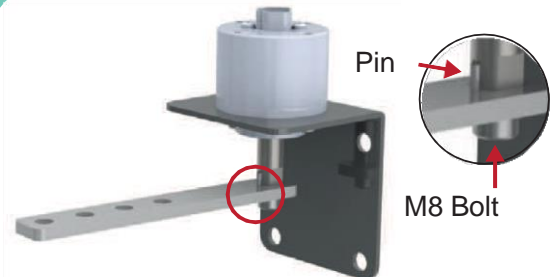
Step 4:

Attach the first articulator (01718) to the sensor arm, with the (01387) locking nut.

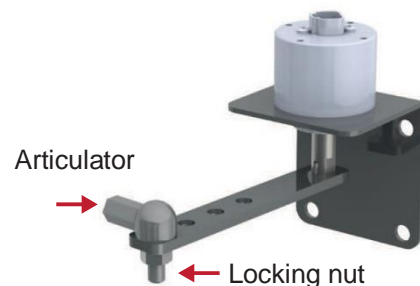

Step 5:

Attach the support on a flat part of the vehicle, near the wheel.

Step 6:

Attach the threaded bar (00114) to the articulator.

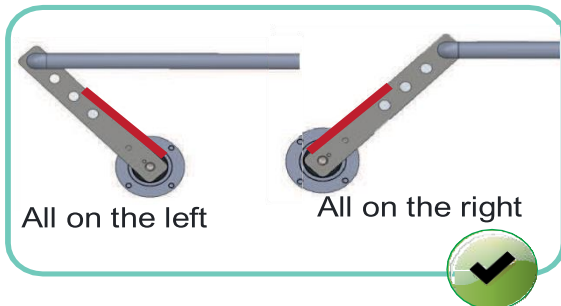
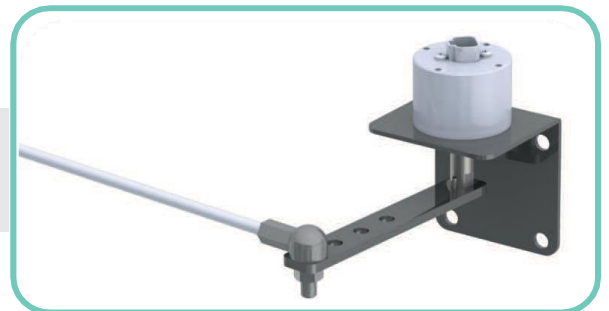

Minimum: greater than 60° .
Recommended: greater than 90° .

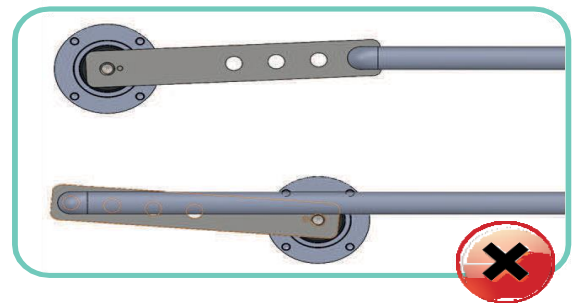

Angles close to 0° (zero) and 180° must not be within the steer limits of the tractor's steering.

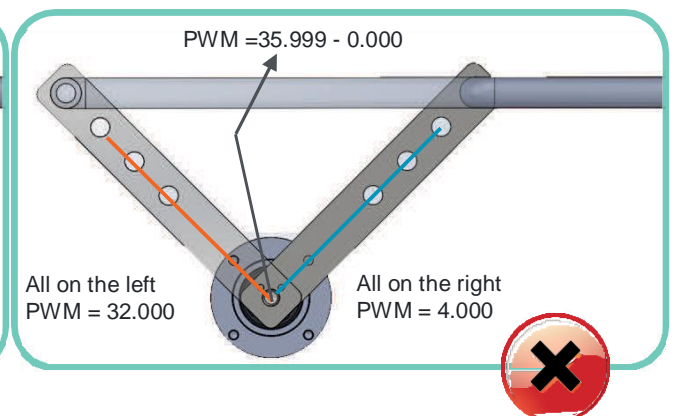
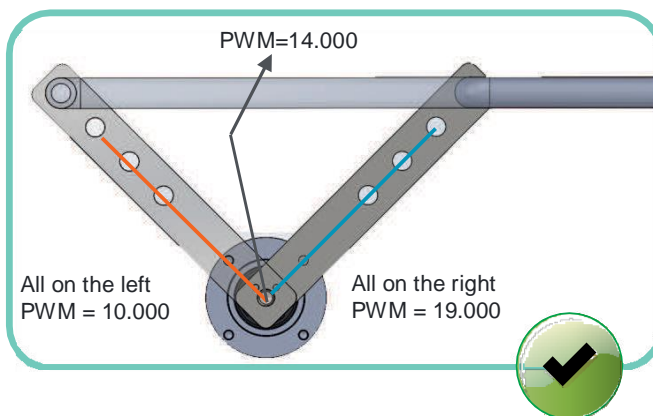

Step 7:

Attach the second articulator in an appropriate location, then, connect the other end of threaded bar to the articulator.

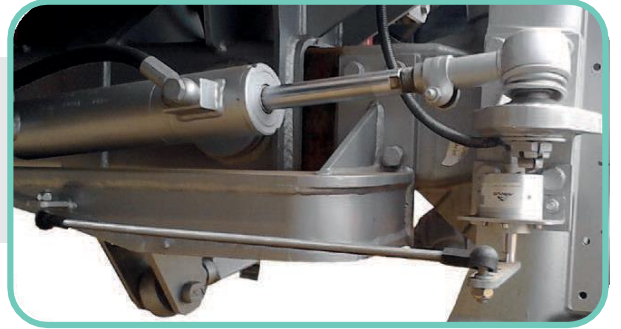
**⚠ WARNING**

Be careful that during movement of the vehicle's wheels, so that the threaded bar does not come into mechanical shock with the vehicle.

5 Electric System Installation

5.1 Installing the ECU (Driver)

 **WARNING**

The Driver must be installed on the same structure as the antenna (vehicle frame) and the closer to the rear axle of the vehicle as possible, so that both the driver and antenna will be receiving the same balancing.

 **WARNING**

Do not attach the driver to surfaces subject to excessive vibration (near the vehicle's engine), or on tilted surfaces.

 **IMPORTANT**

For the correct installation of the driver, check the instructions in chapter 6.5.1.

Step 1:

Make two drillings of 6,5mm on a flat surface of the vehicle, following the measures presented here.

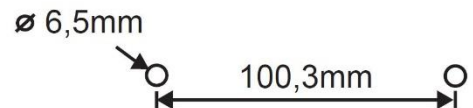

Step 2:

Screw the driver on the tractor with the M6X30 screws and washers. Use the M6 locking nut for fixing it.

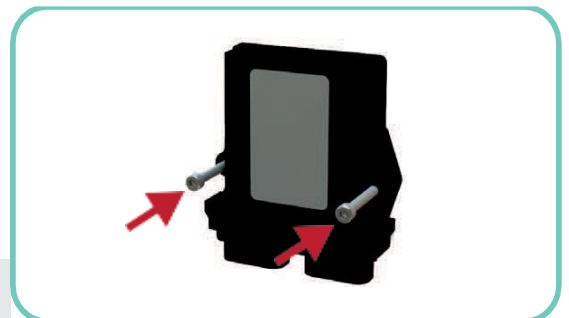

5.2 Harness List

Item	Code	Description
Battery Power Cable 7m – Ti10	06960	Power cable with a 10A fuse for the Ti10 display
Battery Power Cable 7m – Ti7	05697	Power cable with a 10A fuse for the Ti7 display
CAN Harness	01862	Main CAN harness (CAN network).
Antenna cable 7m for Ti10 and Ti7	05709	Cable RG58 7m TNC male 90-degree angle + TNC male 90-degree angle– TM58U-TM001-18-02
Kit Foot Switch DTM04-2P connector	02257	Foot switch with cable.
Adapter Cable DTM06-12S-A CAN	03549	Harness connected to the Driver to receive the CAN from the display, with output for the pressure sensor.
Hydraulic Autopilot Harness	03548	Harness for activating valves and sensor, connected to driver.

To avoid damage or malfunction of the harness:



- Pass the cables away from areas where they may get pinched or rubbed against one another
 - Do not change the lengths of the cables and connections. If you need to change the power cord length does not remove the fuse or the cable fuse holder
-

5.3 ECU (Driver) Pinout

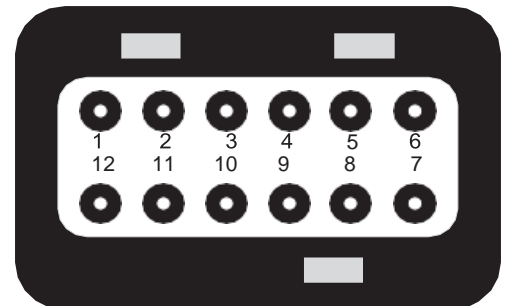
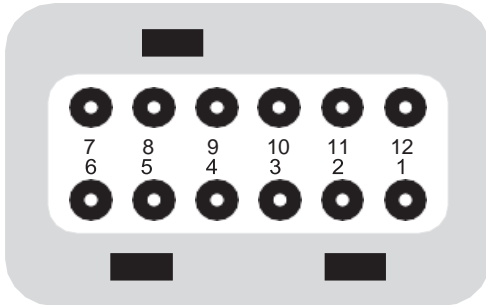

Gray Connector (A)	
1	CAN GND
2	CAN HIGH
3	__
4	__
5	__
6	Pressure Switch (-)
7	Pressure Switch (+)
8	Pressure Switch (Signal)
9	__
10	12V (+)
11	CAN LOW
12	12V (+)

Black Connector (B)	
1	Safety Valve (-)
2	Valve 1 (-)
3	Valve 2 (-)
4	Angle Sensor (+)
5	__
6	__
7	__
8	Angle Sensor (Signal)
9	Angle Sensor (-)
10	Valve 2 (+)
11	Valve 1 (+)
12	Safety Valve (+)

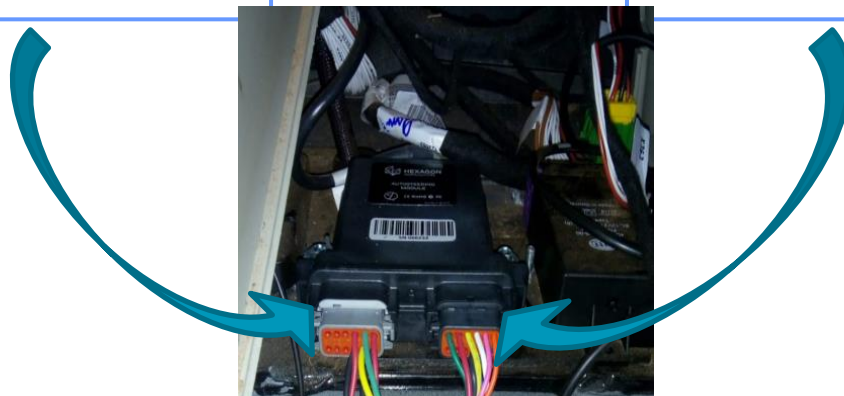

6 Settings

IMPORTANT Regarding the software version used for this manual, all the screenshots and configurations screens were taken based on the SW 3.19.1 version and 2.18.2 FW version.

6.1 Initial Settings

6.1.1 Support Mode

IMPORTANT To access advanced settings, it is necessary to enable **Mode Advanced** or the **Support mode**.

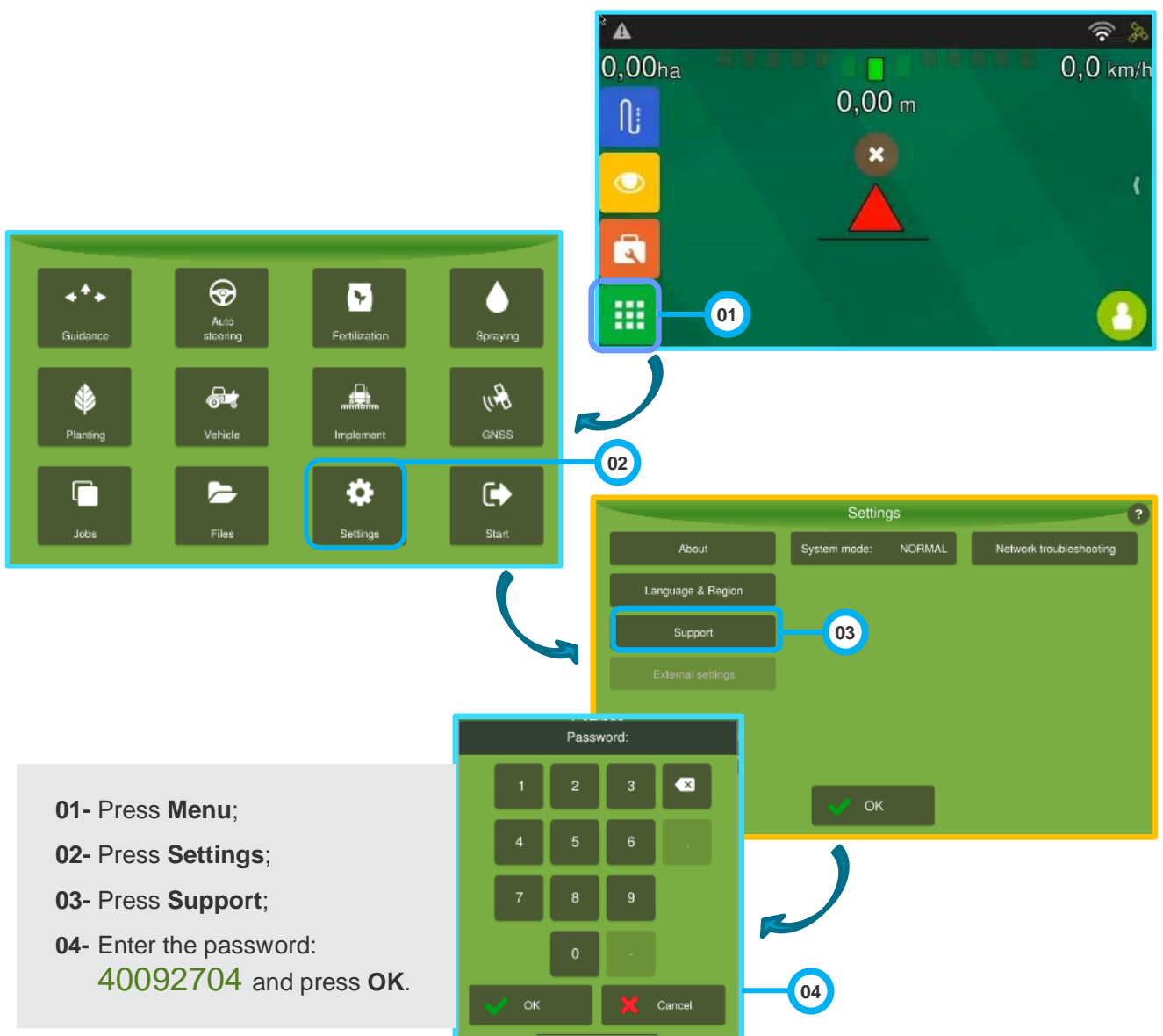

01- Press **Menu**;

02- Press **Settings**;

03- Press **Support**;

04- Enter the password:
40092704 and press **OK**.

6.1.2 Checking Activations



If the monitor in use does not have activation for **Auto Steering**, it will not be possible to configure autopilot settings at this time. To obtain activation, contact Hexagon Support to get the code and information on how to proceed.

How to check:



The screenshots illustrate the following steps:

- 01** - Press **About** in the **Settings** menu.
- 02** - Press **Show activations** in the **About** screen.
- 03** - Check for **Auto Steering** in the **Enabled features** list.

In the **SETTINGS MENU**:

01- Press **About**.

02- Press **Show activations**.

03- Check for **Auto Steering**, if present, activation for Autosteering is OK.

6.1.3 Vehicle Configuration

⚠ WARNING

Whenever a new vehicle is created, the entire configuration, calibration and adjustments steps must be properly fulfilled. All the measurement must be correct.

In the settings menu, press vehicle. Some measurements of the vehicle are necessary for the proper functioning of the autopilot. Each vehicle has its own settings and adjustments (calibration, gains, etc.)

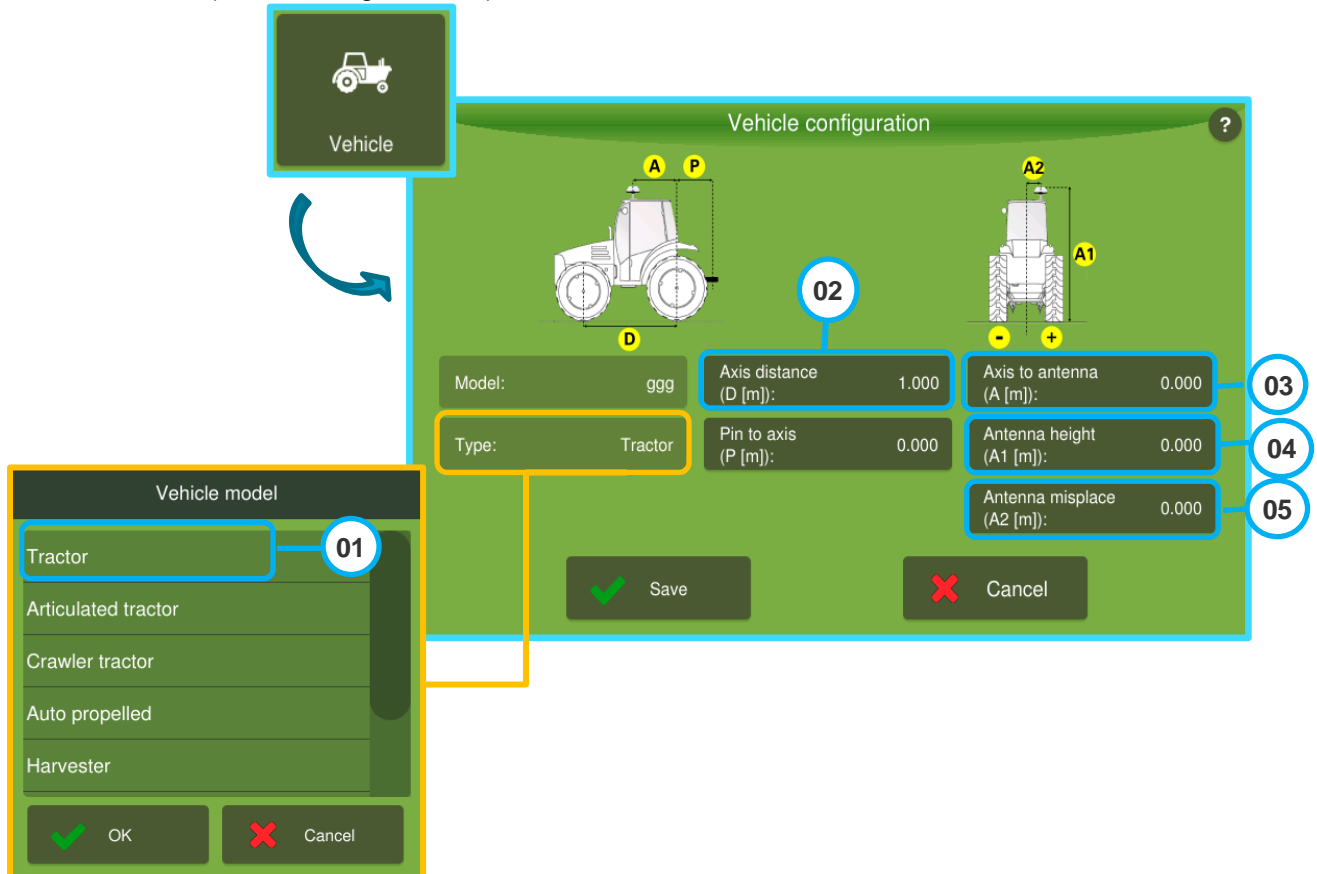

1- Select the type/model that matches the vehicle. Each model has a specific layout that needs to be properly selected because of the measurements. Standard Type: Tractor.

Available models: Tractor, Articulated Tractor, Crawler Tractor, Self-propelled, Harvester, Truck, Excavator and Invalid.

2- Axis distance: Distance, in meters, from the center of the rear axle to the center of the front axle. Fundamental to calculate the control routine.

3- Axis to antenna: Distance, in meters, from the center of the rear axle to the antenna. Necessary for the tilt compensation system, for when approaching a new guideline and for curve guidelines.

⚠ WARNING

The antenna should be installed, preferably, near the rear axle. Must be, always, ahead of the rear axle, never behind.

Its target field must be free of objects (hoods, air-conditioning, cabin, etc.). The ECU (driver ATCD) and antenna shall be installed in the same structure (same buffer) and, if possible, with similar distances from the rear axle.

4- Antenna height: Distance, in meters, from the ground to center of the antenna. This measure is fundamental for the tilt compensation system and parallel lines.

5- Antenna misplace: Distance, in meters, of the lateral displacement of the antenna. Fundamental to the parallelism of the lines.

6.2 Auto Steering Settings Menu

In the autopilot settings menu, we have the following buttons:

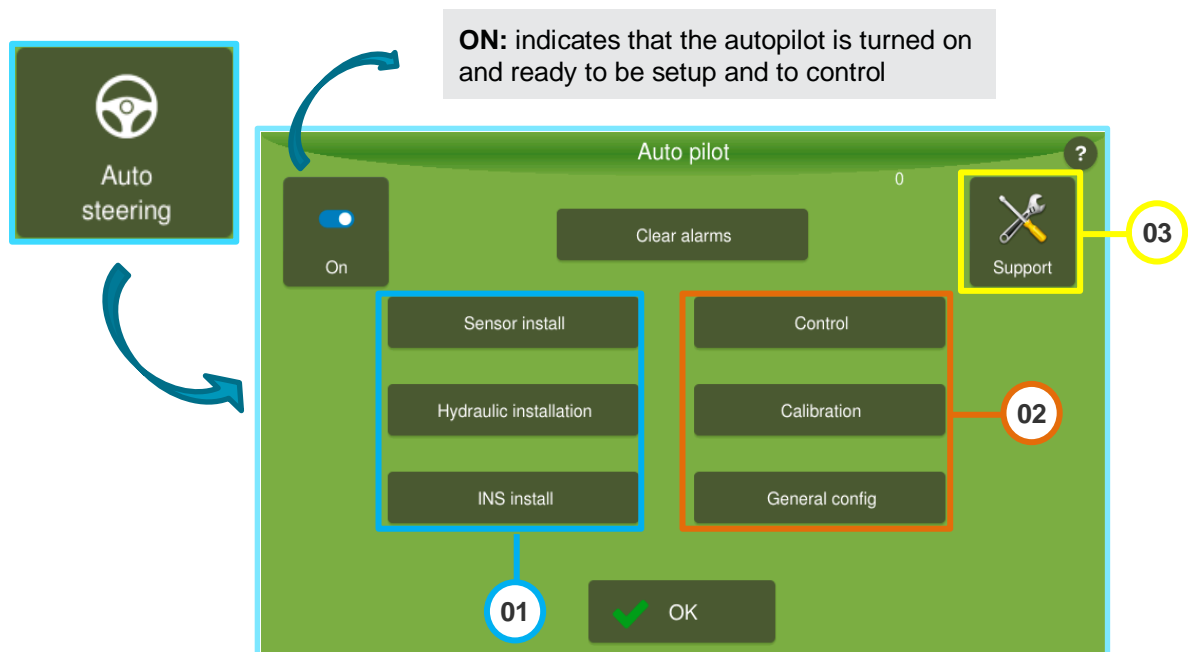

01 - Basic Mode

- Sensor install
- Hydraulic installation
- INS Install

02 - Advanced Mode

- Control
- Calibration
- General config.

03 - Support Mode

- Support

6.3 Support Mode

IMPORTANT Enter the support menu to configure the correct autopilot model (**Hydraulic**).

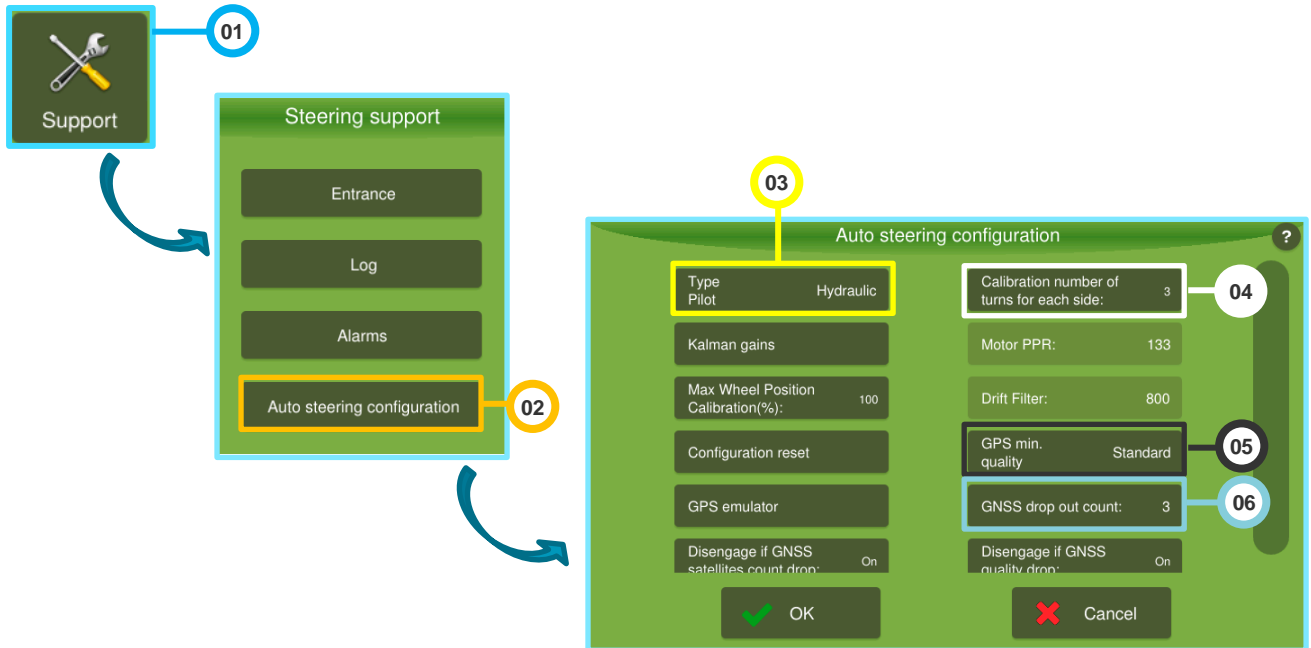

01- Press the **Support** button;

02- Press **Auto steering configuration** button;

03- In **Type Pilot**, select the **Hydraulic** type.
Usually, the default model is the Electric Pilot;

04- Calibration number of turns for each side, determines the number of turns in penultimate and last calibration step. (**Topic 6.5.5**).

05- GNSS minimum quality: Allows you to select between four signals type:

- High precision (a more basic precision, using only the Novatel Glide satellite).
- Standard (signal without any kind of correction, with elevated error)
- RTK (2 centimeters, using RTK correction)
- Charged Signal (2.5 absolute centimeters, guaranteed by the TerraStar C PRO from Novatel)

06- GNSS drop out count: Disable the auto steering if it this counting drops below three.

6.4 Tests

6.4.1 Wheel Sensor Installation

Assists in checking the operation and installation of the wheel sensor. To run the test, go to Autopilot -> Wheel Sensor Installation.

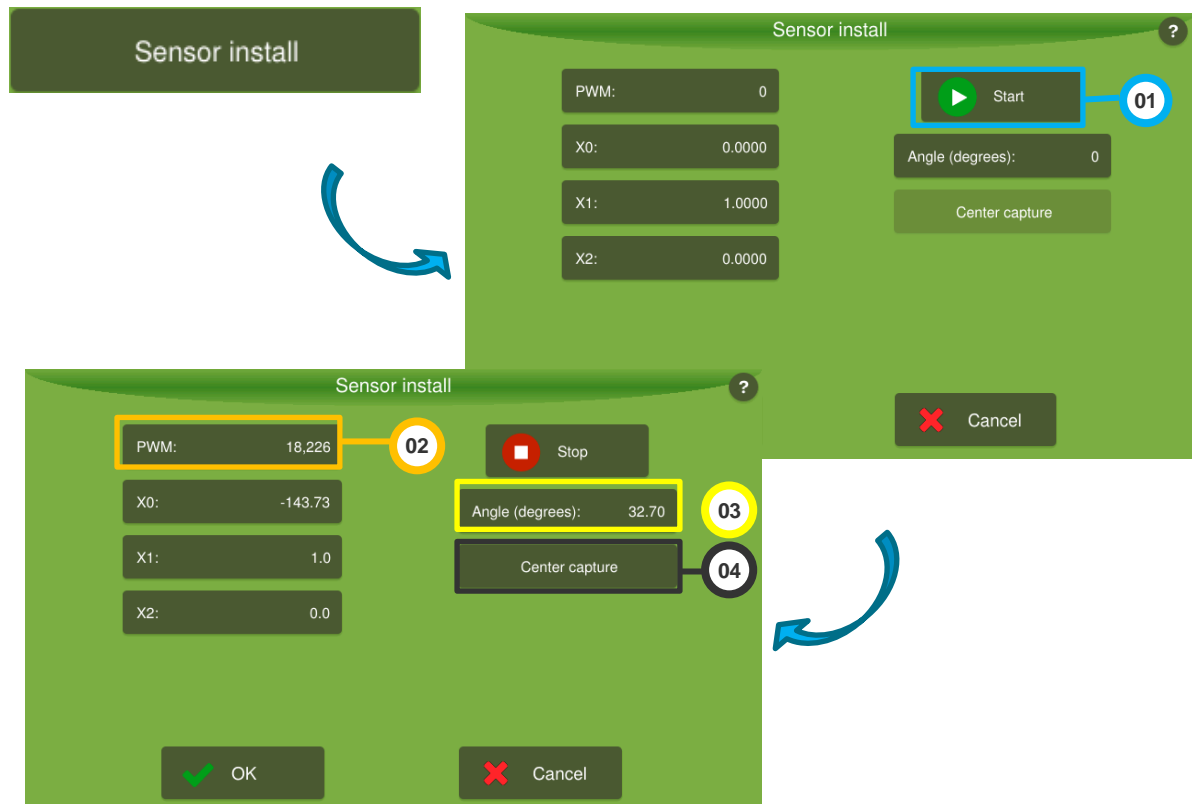

01- In the sensor install screen, click on **Start**.

02- PWM will display the raw value reading, which ranges from 0 to 36000.

Note: Make sure the sensor is able to capture any wheel movement.

It is important that when the vehicle wheels are aligned, the value read in the PWM field is in the middle reading range. Avoid values close to 0 and 36000. If necessary, reposition the sensor to suit the recommended reading range. To do this, simply remove the sensor from the support and reposition it in the opposite position.

The PWM must have a minimum variance of 9000. For example, when the steering wheel is all the way to the left and has a PWM value of 15,000 and all the way to the right at 24,500, we get a variance of 9,500, satisfying the condition.

03- **Angle (degrees)** shows the sensor reading converted to angle. When turning the wheels to the right, the value must be positive, negative to the left.

Note: A range of motion of at least 60 degrees must be allowed. If the reading difference between the maximum right and left angle is greater than 10 degrees, the mechanical coupling installation must be reassessed.

04- Center the wheels, click **Capture Center**. This action will make the system recognize the positioning of the wheels, which is necessary for the next steps.

Note: Do not capture center after calibration is finished, this will delete the values found in the calibration.

6.4.2 Hydraulic Installation

To perform the valve installation test, press Pilot menu -> Hydraulic installation. This test assists in checking the operation and installation of the hydraulic valve.

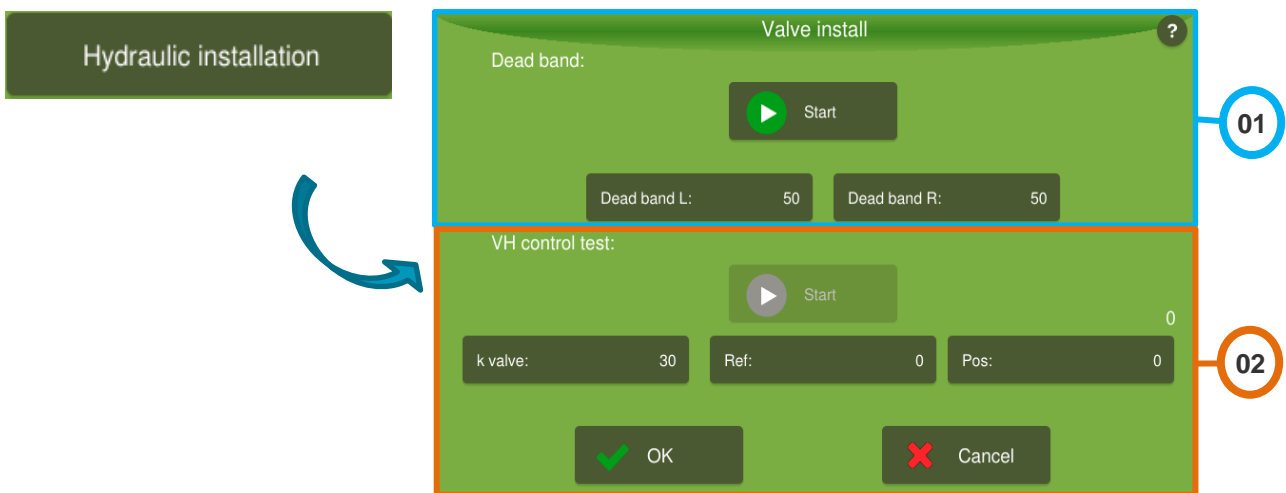

01- Dead band test:

Determines the minimum trigger to initiate wheel movement and is performed automatically after pressing **Start**.

02- VH control test:

Test wheel control. Pay attention to the adjustment of “K Valve”, high values make the wheel oscillate. Low values tend to have a slow response, which impairs performance.

6.4.2.1 Dead Band Test

-
-  **IMPORTANT**
- Do not perform the dead band test on sandy or soft ground.
 - When performing the drive test, if the wheels move in the wrong direction, you can reverse the connectors on the solenoids, (only after verifying that the wheel sensor is reading positive values to the right).
-

The Dead Band Test identifies the minimum voltage that must be applied to the actuator in order for the wheels to start moving.

How it works:

The system will automatically increase the voltage applied to the valve terminals, starting from zero, until the movement of the wheels is detected (variation of about 0.5°).

How to proceed:

1. Align the vehicle's wheels.
2. Accelerate to 1500 rpm.
3. Press **Start**.
4. Wait until the test finishes the step of the dead Band **R** and the dead Band **L**. The value in the field Dead zone will be modified to the calibrated value and the Start button will have its state changed.

 **WARNING** Do not use the steering wheel or change the position of the vehicle's wheels during the test.

 **IMPORTANT** The value obtained for the Dead Band after calibration is around 300. (It is recommended to redo the test if the value is very different from this one.).

6.4.2.2 VH Control Test

Test to verify the correct functioning of the wheel control system, as well as confirm the correct installation of the hydraulic valve.

 **WARNING** Make sure the wheel sensor is working properly.

If the wheels turn in the opposite direction than expected, or any other unforeseen event occurs, turn off the equipment immediately to avoid any damage.

How to proceed:

1. Press **Start**.
2. Change the values in the **Ref** field (positive and negative). Positive values will turn the wheels to the right, negative values to the left. Example:
 When entering the number 15, the wheels must turn to the right.
 When entering the number -15, the wheels must turn to the left.
3. Observe the response, if it is slow or the difference between the value read in the **Pos** field and **Ref** are greater than 1, increase the value of the **K valve** field. If the steering keeps moving by itself, reduce the value in **K valve**.

Field	Description
Field K valve	Hydraulic valve response speed. <ul style="list-style-type: none"> • Low values will cause the system to slow down, in addition to presenting a greater error following the reference. • Higher values result in a faster response and reduced position error, however too high values tend to cause the wheels to oscillate.
Field Ref	Value that indicates the position (in degrees) to which the wheel will go during the test. <ul style="list-style-type: none"> • Positive values cause the wheel to turn to the right. • Negative values cause the wheel to turn to the left. For security reasons, the values entered are limited to the range of -15° to 15°.
Field Pos	Indicates the wheel position provided by the sensor.

6.4.3 INS Install

The values shown on the following screen depend on your tractor's current position:

NOTE: these values are going to be collected during the calibration steps ahead. There is no need to do these tests right now.

01 – Typical values up to 2,0000.

02 – Typical values up to 10,00.

INS install

INS installation

?

Roll: 2.83

Pitch: -3.03

Yaw: 180.00

Stop

Gyro X: 0.0000
01

Gyro Y: 0.0000

Gyro Z: 0.0000

Roll offset (degrees): 0.00
02

Pitch offset (degrees): 0.00

✓ OK

✗ Cancel

How to proceed:

01- Position the tractor horizontally and click **Start**.

02- Tilt the tractor to the right. Reading **Roll** should go to a negative value turning to the left, reading **Roll** should go for a positive value.

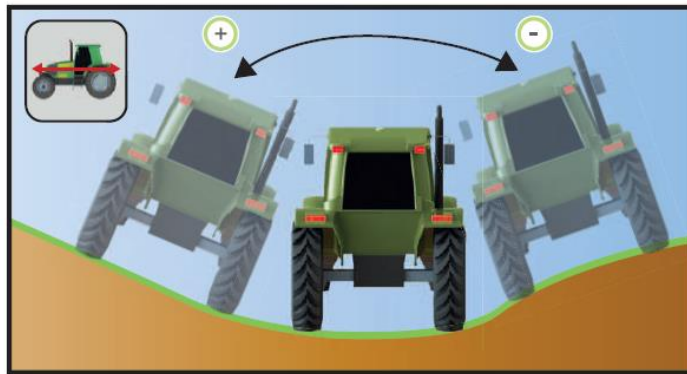

03- Turn the tractor forward. The **Pitch** reading must be a negative value.

04- Turn back so that the Pitch reading is a positive value.

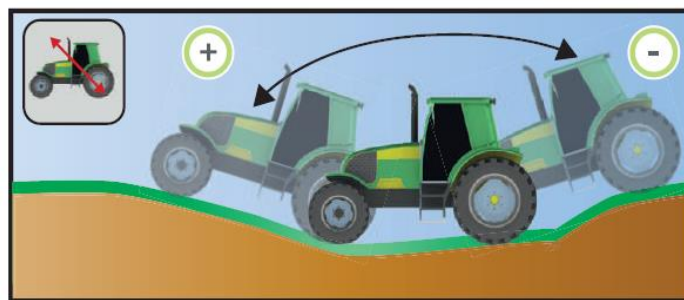

05- The **Yaw** reading will only be different from zero with the moving vehicle

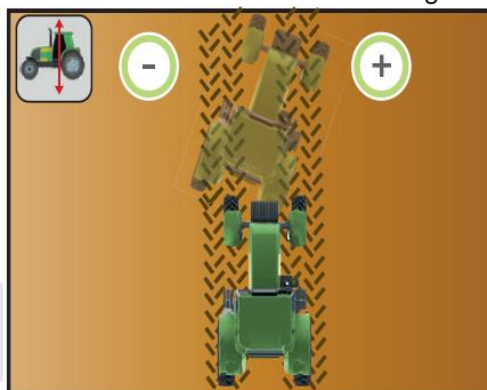

Clockwise: +
Counter clockwise: -

 **WARNING**

Check that the value shown when leaving the tractor stationary stabilizes quickly and that there is no overpass (go to a high reading and then decrease). If this occurs, or there are differences in the values read, check if there is a problem with the driver assembly or if there is a defective component.

6.5 Calibration

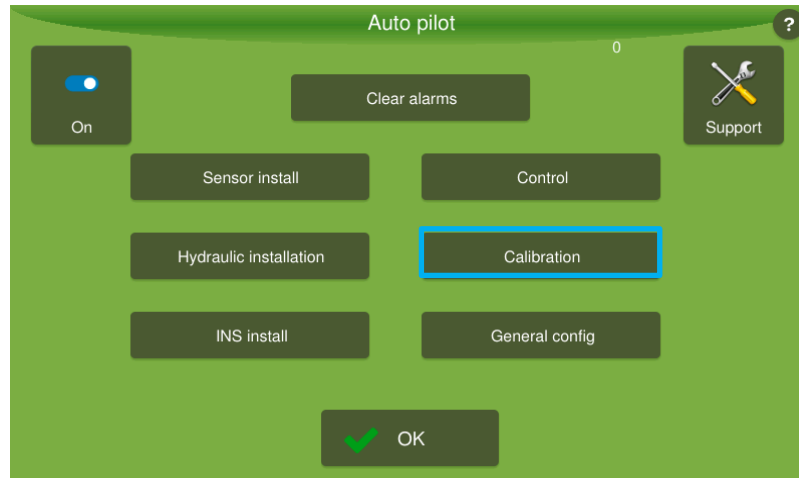

In the calibration screen, it is possible to configure the following parameters of the equipment.

- Driver position.
- Accel/rotate calibration.
- Gyro calibration.
- Wheel sensor tests.
- Clockwise/counterclockwise calibration

6.5.1 Driver Position

Inform the monitor of the installation position of the control driver (ECU).

Before starting the test, be aware of the following facts.

- Do not rock the vehicle during this step.
 - As the test is carried out in two stages, it is necessary to move the vehicle and it is recommended to make markings on the ground so that the tests can be carried out without excessively altering the relief characteristics of the ground.
 - Carry out the tests on a flat surface.
 - Whenever the driver is removed from its position (whether for cleaning or any other purpose) this step must be redone, even if the device has been fixed in the same place.
-

 **WARNING**

Choose the correct driver installation position, opening the option where it is: **1-Horizontal front** - select the one that is in accordance with the installation and press the **Next** button.

Look at the example.

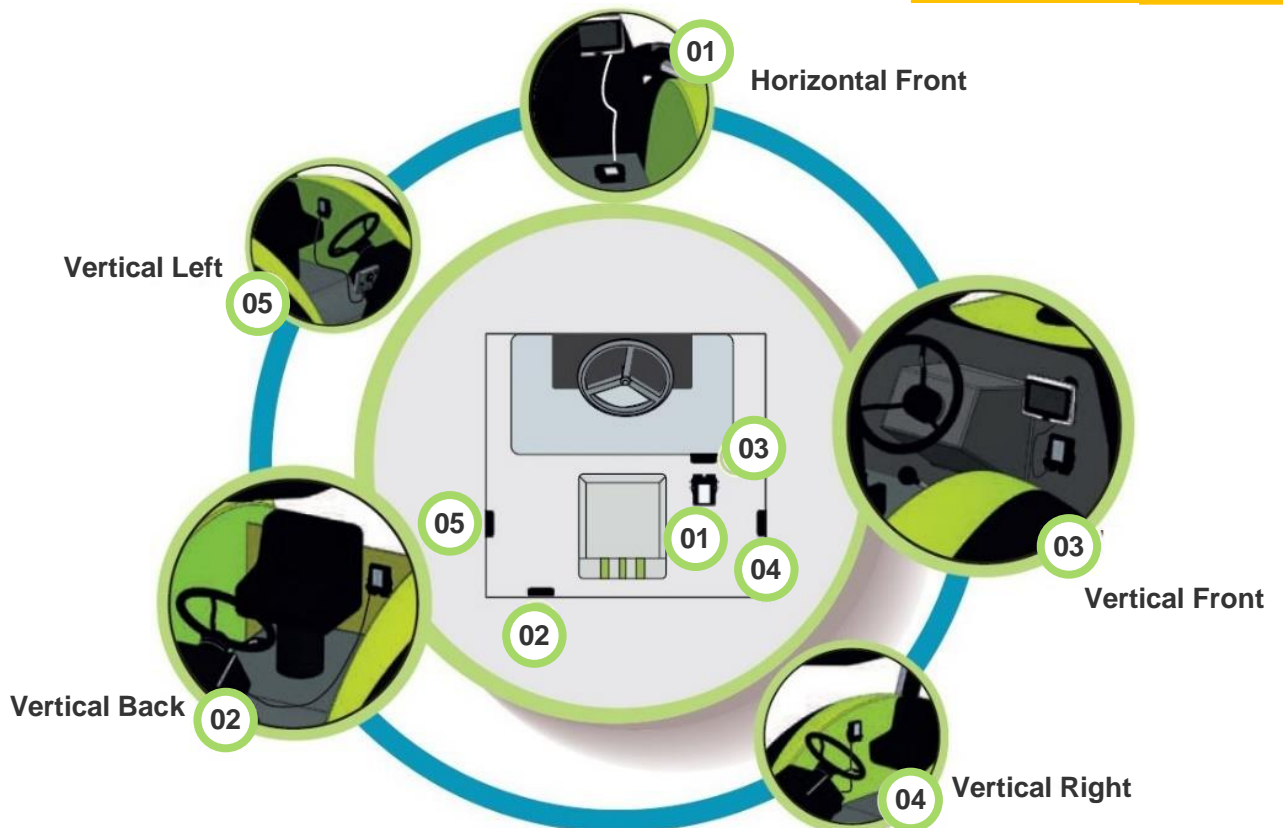
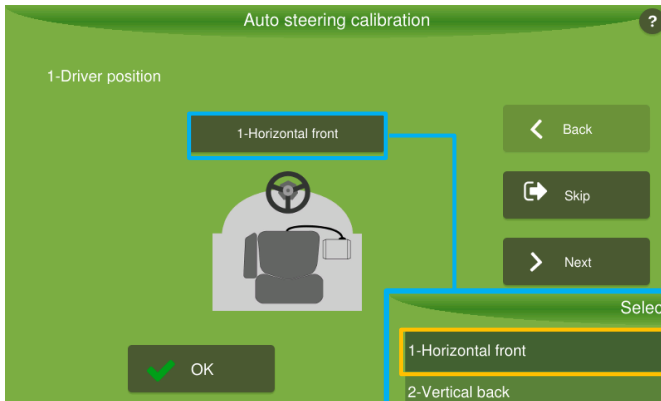

HORIZONTAL POSITION



Output cables lie ahead

VERTICAL POSITION



Cable output toward the ground

6.5.2 Accelerometer Calibration

Determines the relative position (roll and pitch angles) between the vehicle and the position of driver installation.



WARNING

- Perform the test with the engine at operating speed.
- Do not rock the vehicle during this step.
- Do not move the vehicle during the test.
- Perform the test at a flat level.
- If the result shows any angle (roll or pitch) with more than 10 degrees, it is recommended, reassess the installation position (the slope compensation cannot operate as expected).

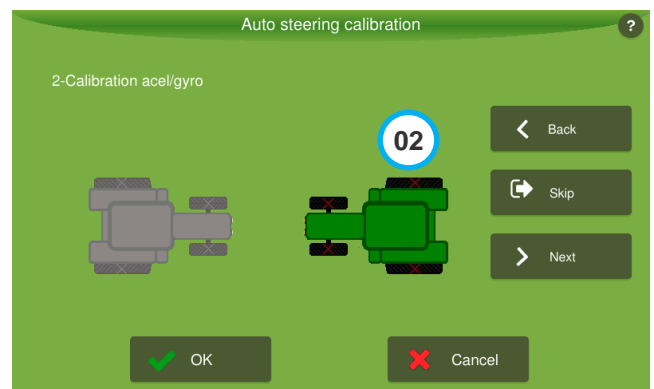
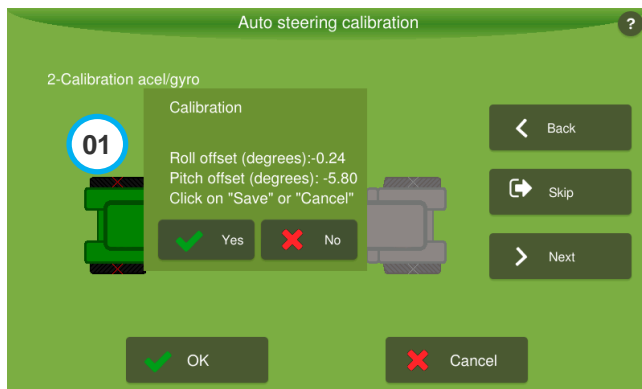

01- Raise the engine speed for the job (1500-2000rpm).

02- Tap the left tractor image (01) and wait 10 seconds.

03- Wait for the right tractor image to be enabled (green), on the ground, mark off the placement of the four wheels of the vehicle.

04- Maneuver the vehicle and come back to the same spot, putting the front wheels where the rear wheels were before, and the rear wheels should be placed where the front wheels were previously.

05- Press the right tractor image (2) and wait for 10 seconds.

06- When both images are green, a window appears showing the values found. Press **OK** to save and press **Next**.

6.5.3 Gyroscope Calibration

It aims to estimate errors present in the data provided by the gyroscopes.

Do not move or rock the vehicle during the test.

⚠ WARNING This test is performed automatically whenever the vehicle is stationary.

Values greater than 5 degrees/second may indicate a component malfunction.

DO NOT move or rock the vehicle while performing this step.

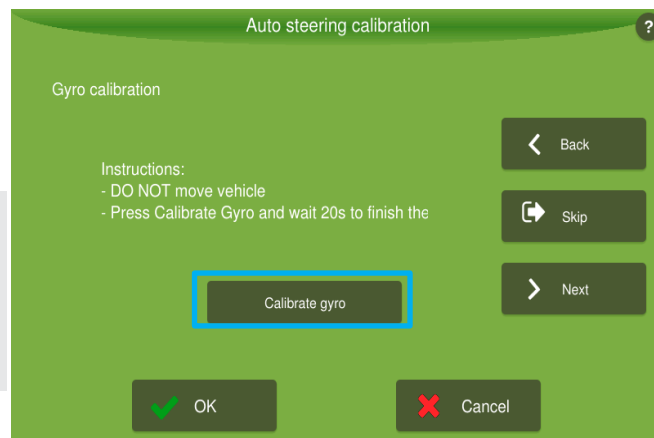

How to proceed:

1. Raise engine speed to working speed (1500-2000rpm).
2. Press the Calibrate Gyroscope button and wait for the bar to fully load.
3. After 20 seconds a window will appear with the values found. Confirm with **OK** so that the data is saved.

6.5.4 Steering Reading Calibration

NOTE: In this step, the four steps are performed with the command in this same field, which will update the information according to the progress:

- 1 Save reading (center)
- 2 Save reading (left)
- 3 Save reading (right)
- 4 Test Commands.

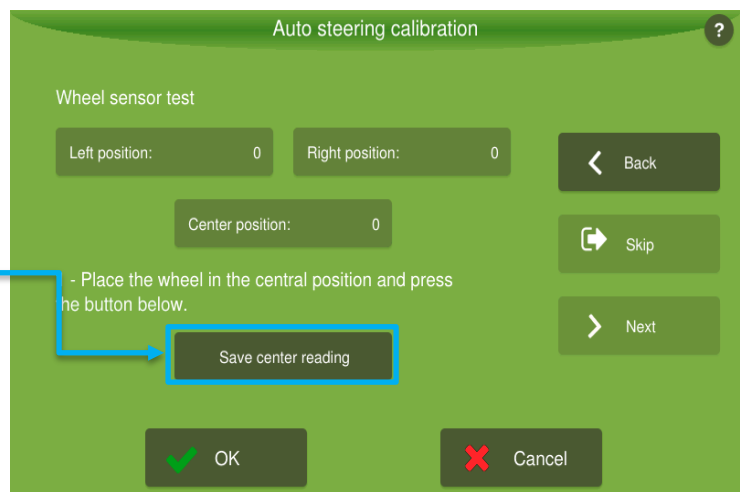

How to proceed:

1. Position the wheels in the central position, with the vehicle stationary and looking at the alignment of the wheels so that they are well centered. After centering, press **Save Reading Center**.
2. Steer the wheels all the way to the left and press **Save Left Reading**.
3. Steer the wheels all the way to the right and press **Save Right Reading**.
4. Then return the wheels to the center position for the system to enable the field again with the Test Drive option. Press the **Test Commands** button, leaving the wheels and steering wheel free.
5. When testing the **Commands**, confirm OK to finish the installation the wheel position sensor and press **Next** to proceed with the calibration.

6.5.5 Clockwise and Counterclockwise Calibration

Before starting the test, be aware of the following facts:

**WARNING**

Clockwise means the vehicle will circle to the right, counterclockwise means the vehicle will circle to the left.

**IMPORTANT**

This step requires the vehicle to be in motion, requiring a wide area, without obstacles, for its completion. A total of 3 turns clockwise and three turns counterclockwise can be performed.

It is extremely important to know if there is enough space to make a wide circle, otherwise, you must inform that you will be doing only 2 turns or 1 for each side. In this case, an intermediate turn and a smaller one, or just the smallest one of all. Proceed to topic 6.3 **Assistance Mode, item 3, Number of calibration turns for each side** and reduce from 3 to 2 or 1, depending on the space available.

How to proceed with Clockwise and Counterclockwise calibration:

1. Position the vehicle in an area free for travel and press Start.
2. The wheels will automatically be positioned to the right position, move the vehicle to the conclusion of the turns to the right, following the steps and the progress of the steps in each turn.
3. At the end of the right turns the vehicle will automatically position the wheels to the left. Check the space for left turns, or press Stop, reposition the vehicle and press Start again.
4. When completing the last turn to the right, the calibration values will appear, confirm **Yes** and press **OK** to save the entire calibration process.

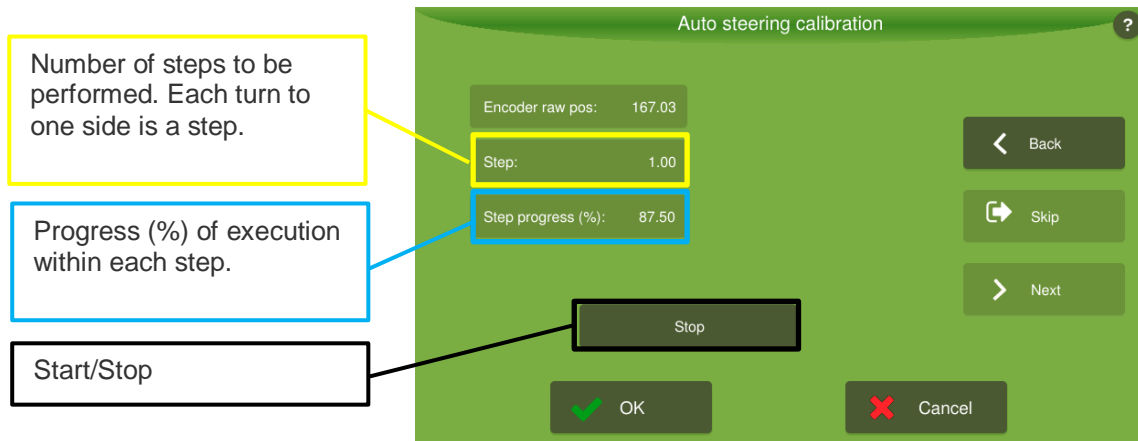

6.6 General Configuration Hydraulic Autopilot

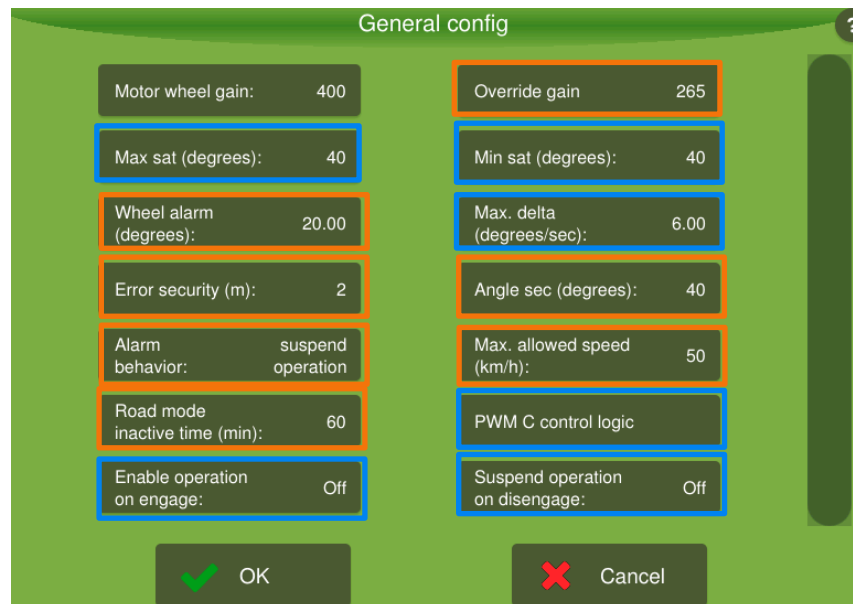

■ Security Parameters

■ Operation Parameters

Security parameters:

- **Wheel alarm:** Checks operation of the wheel sensor, in case of anomaly, deactivates the autopilot.
- **Error security:** Blocks the use of the autopilot if the error is above the configured one.
- **Alarm behavior:** Indicates whether autopilot alarms will suspend operation or not (section cutting, fertilizing, etc.).
- **Road Mode Inactive Time:** Corresponds to the time configurable by the operator for the pop-up warning to appear. This warning is for autopilot downtime.

- **Override gain:** Parameter for setting the manual disengagement of the equipment (operator acting in the direction with the equipment turned on). The higher the value, the more difficult to disengage, the lower the value, the more sensitive to disengage.
- **Angle security:** Blocks the use of the autopilot if the angular error, in relation to the guide, is above the configured one.
- **Maximum allowed speed:** Corresponds to the value that the user wants to use as the cutting speed in the operation. If the equipment is operating above the configured maximum speed, it will not be possible to turn on the autopilot. If the equipment exceeds the maximum speed configured with the autopilot on, it will be disarmed.

Operation Parameters:

- **Max sat.:** Maximum steering angle at low speeds.
- **Min sat.:** Maximum steering angle at high speeds (25km/h).
- **Max. delta:** Wheel turning speed.
- **PWM C Control Logic:** Setting the third output of the steering driver. It is possible to configure the C MOTOR output when using power steering.
- **Enable operation on engage:** If turned on, starts application/painting when autopilot is engaged.
- **Suspend operation on engage:** If turned on, stop spraying/painting when autopilot is disengaged.

Low values for these parameters tend to impair the autopilot's entry and response on the curved guide (slowness to perform maneuvers).

 **WARNING**

High values of Sat Min and Delta Max can cause sudden movements of the equipment, which impairs the safety of operation at high speeds.

6.7 Control Adjustments

Parameters that help the autopilot's performance, allowing it to adapt to different working conditions. They are **Overshoot**, **Aggressiveness**, **Sensitivity**, **Speed Gain (%)** and **Aggressiveness in curve**.

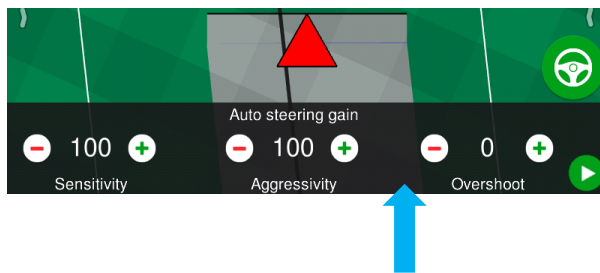
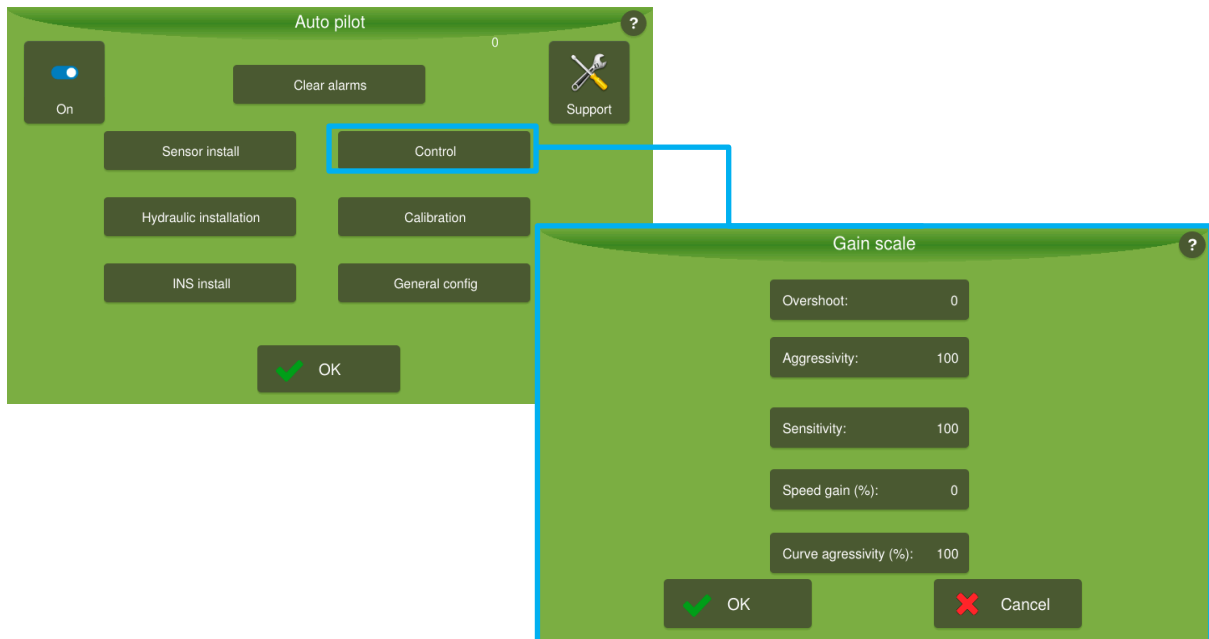

On the operation screen, dragging from bottom to top, as shown in the image, it is also possible to access the main parameters: **Sensitivity, Aggressiveness and Overshoot.**

6.7.1 Overshoot

Overshoot controls the rate the vehicle will drive on the line and the rate the vehicle will finish as it approaches the line. The default value is zero, and it should only be changed if it is not possible to eliminate the over signal through Aggressiveness and Sensitivity.

1. Parameter ranges from 0 to 200 (**default value: 0 - disabled**).
2. A low value tends to make the autopilot converge more slowly to the line, reducing overshoot.
3. A high value tends to make the autopilot attack the line more aggressively, probably increasing the overshoot

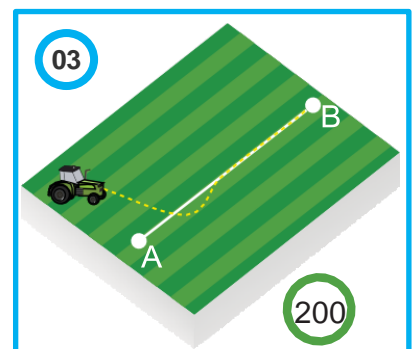
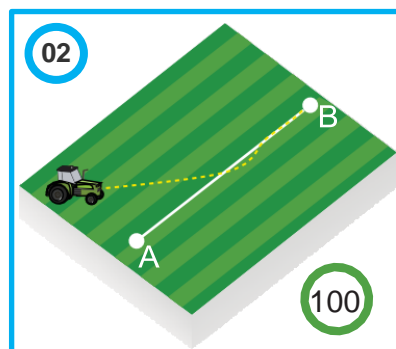
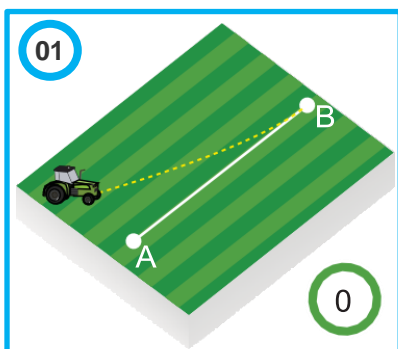

6.7.2 Aggressiveness

Aggressiveness controls the rate at which the vehicle attacks the line and how well it stays on the line. It can be set between 0 and 200. The default setting is 100. It operates mainly during input.

1. A high value tends to cause the autopilot to zigzag control
2. A low value tends to make the autopilot align quickly and slowly converge the error to zero

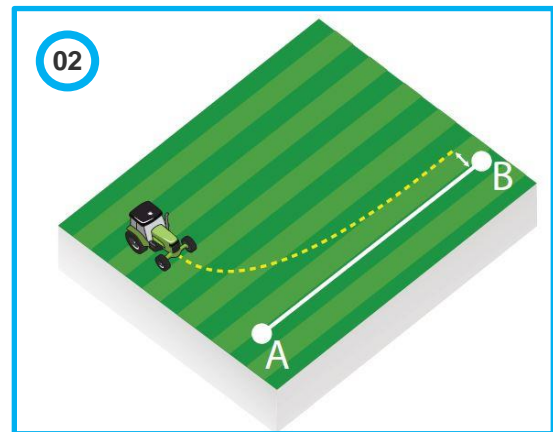
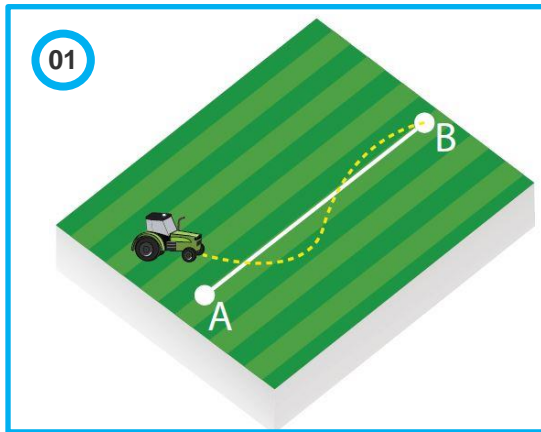

6.7.3 Sensibility

Sensitivity controls the rate at which the vehicle turns and its sensitivity when on the line. It acts, mainly, when on the line.

1. A high value tends to make the rider respond quickly to small variations in the ground (sway, etc.) which can cause him to travel in a zigzag, acting too much on the wheels.
2. Low value tends to make the autopilot take longer to respond to error variations.

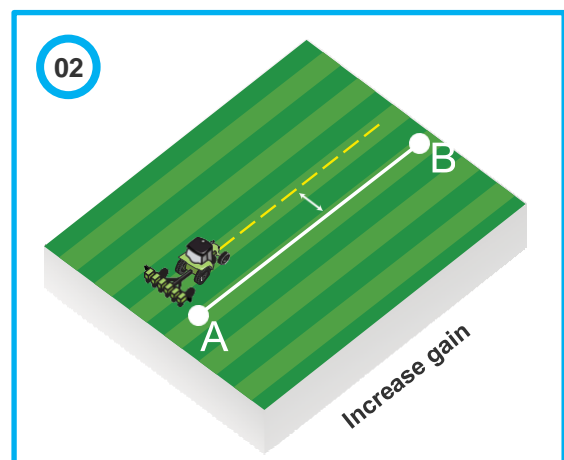
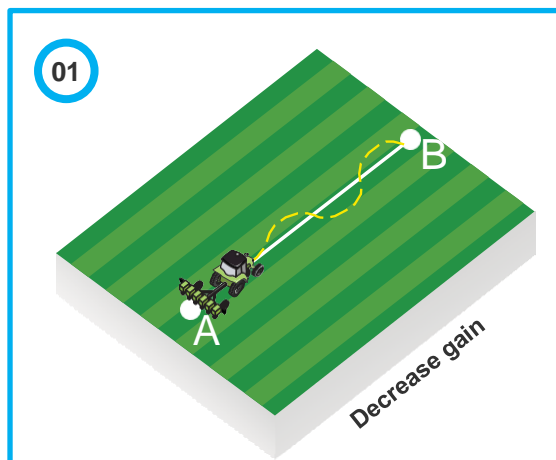

6.7.4 Speed Gain (%)

Speed gain adjusts the gains (Aggressiveness, Sensitivity and Overshooting) automatically based on vehicle speed

1. If the application has large speed variations during operation, set the gain to 100% and adjust the options for aggressiveness, sensitivity and overtaking, operating at 7km/h to the values that best suit your needs. After this initial adjustment, use the autopilot in another speed range and observe the response.
2. If the autopilot is slowly converging to zero error, increase the value for speed gain.
3. If the autopilot is oscillating, reduce the speed gain. When setting the gain to zero, the system will not change the gains automatically, based on vehicle speed (ideal for applications with low-speed variations +/- 3 km/h).

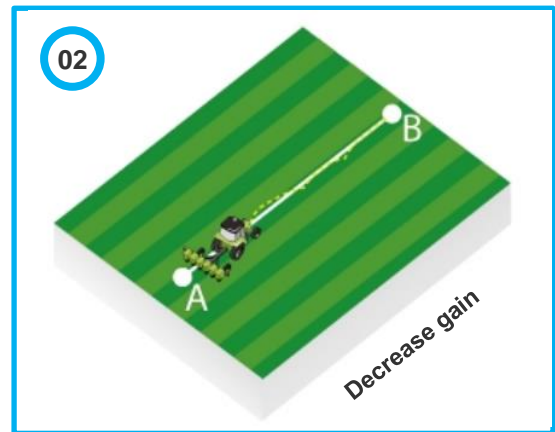
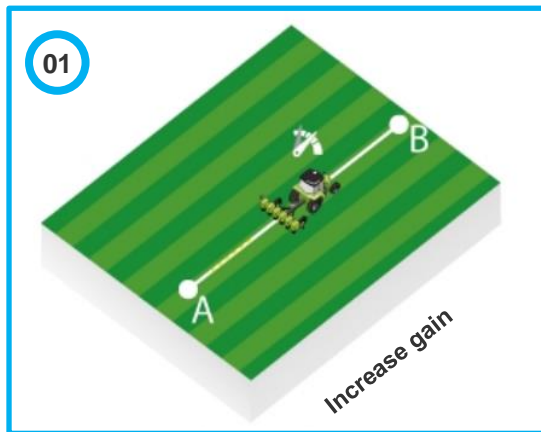

6.7.5 Curve Aggressiveness

Assists adjustment in following curved trajectories.
Parameter ranges from 0 to 200 (default value: 100).

1. A high value tends to make the rider make sharper turns than necessary, in addition to moving the wheels sharply.
2. A low value tends to make the rider turn more open than they should by moving the wheels smoothly

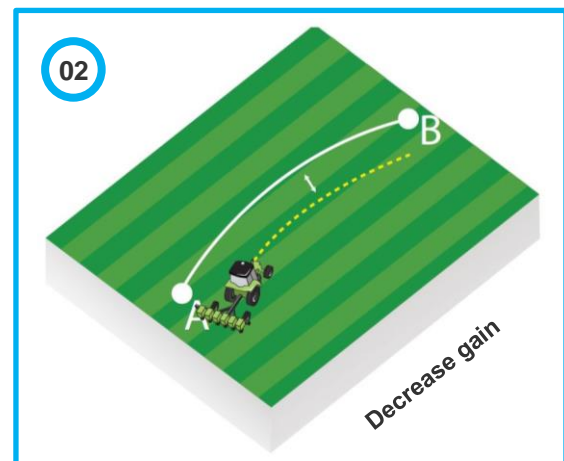
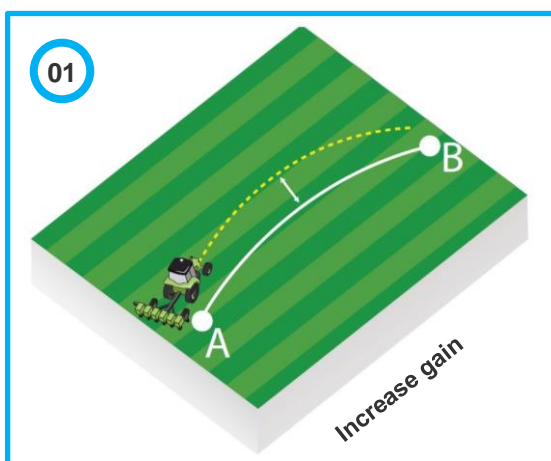

6.7.6 Techniques and Recommendations for Adjustments

1. Note the entry line (Linear guide):

Activate the autopilot, after being properly calibrated, with the factory gains.

Aggressiveness:100

Sensibility:100

Overshoot: 0

 **WARNING** Carry out the adjustment close to the working speed.

Field	Description
If oscillatory response, zigzag trajectory, aggressive response (moving the wheels quickly) or crossing the line too much (> 30 cm).	Reduce Aggression and Sensitivity together until you get a stable and safe response.
If slow response, slow convergence to null error, alignment away from reference line.	Increase aggressiveness and sensitivity together until you get a satisfactory response.

2. Aggressiveness and Sensibility Adjustment:

After obtaining a stable and safe response to the input, adjust the aggressiveness and sensitivity separately for the best possible performance.

Increase the aggression for a greater 'attack' the line during entry. In case the autopilot is very aggressive or with great over-signal, reduce the parameter.

During operation on the line, if the autopilot is acting too much on the wheels, with a tendency to zigzag trajectory, reduce the sensitivity value.

If taking too long to respond to terrain slope variations, tendency to walk parallel to the line with >1cm error, increase sensitivity.

3. Overshoot Adjustment:

The overshoot value must remain zero (0) and must be changed only under special conditions.

4. Curve Gain:

First, aggressiveness and sensitivity must be adjusted during operation for the linear guide.

 **WARNING**





The Sat Max, Sat Min and Delta values (available in the General Settings menu) directly affect the response to the curve guide. Low values for these parameters tend to slow down the response. Raising the gain curve in this case does not improve performance.

6.8 Operation

On the operation screen, check if the icon is active.

i IMPORTANT If the icon is disabled, select Menu > Autopilot and check if the icon is On. **(Item 6.2)**.

To activate the hydraulic autopilot, press On in the operation screen. To turn it off, press the same button, force the steering wheel with your hand to exit autopilot mode, or use the foot switch pedal to turn it on/off.

Icon	Description
	Pilot On - Equipment is on and controlling the direction.
	Enabled Autopilot - Equipment is ready for operation.
	Autopilot Blocked - Equipment cannot be triggered. Critical alarm occurrence (which makes operation impossible). Error and angle in relation to high guide.
	Autopilot Unavailable - Autopilot not communicating with the control driver.

7 Problems and Solutions

Problems	Causes	Solutions
Problem 1 Equipment does not turn on.	Poorly fitted power connector.	Fit the connector correctly.
	Blown up/poorly connected power harness fuse.	Check the fitting and replace the fuse if it is blown up.
	Inverted battery wires.	Fix the wires correctly: red (with fuse holder) on the positive pole and black on the negative pole.
	Battery voltage too low.	Replace battery/alternator maintenance.
	Broken or short-circuited power harness.	Preferably, replace harness or repair it.
Problem 2 GPS Alert Synchronizing.	Condição atmosférica.	Aguardar condição favorável.
	Antenna not visible to the open sky.	Place the antenna free of obstacles, such as a shed or trees.
	Defective antenna cable.	Harness maintenance/replacement.
	Defective antenna.	Antenna replacement.
	Defective equipment.	Maintenance in technical assistance.
Problem 3 GPS No Communication Alert.	Wrongly configured communication port.	Configure the port in GNSS.
	Wrong GPS model configured.	Contact Hexagon's technical department.
	Defective GPS board/controller board.	Maintenance in technical assistance.
Problem 4 Frequent loss of GPS signal.	Ionospheric Flicker.	Avoid using the equipment at times of day when the effect is strongest.
	Very rugged area.	The antenna needs a minimum number of satellites to work properly.
	Antenna too low/incorrect position.	Place the antenna on the tractor roof, on the longitudinal center line.
	Bad contact in the antenna cable.	Cable maintenance/replacement.

Problems	Causes	Solutions
Problem 5 Autopilot does not improve response by modifying gains.	Changing aggressiveness and sensitivity does not improve performance.	Problem in the mechanical installation or configuration of the equipment.
	Autopilot exhibits the same behavior with high or low gains.	Check vehicle configuration.
		Check operation of inertial sensors (INS - INS Installation menu).
		Check if the driver (ATCD) is screwed correctly.
		Check Valve Dead Zone.
		Check Valves Gain.
Problem 6 Error is not reset.		Check operation and calibration of the wheel sensor.
		Check operation of inertial sensors (INS - INS Installation menu).
		Check if the driver (ATCD) is screwed correctly.
Problem 7 Nothing happens after starting the autopilot sensor installation test.		Check if the driver driver is recognized on the network (Menu Information > Network diagnostics). If it is not found, check power supply as well as cable continuity.
		Carry out inspection of the sensor power cable, verifying continuity and whether the voltage between pins "3" and "1" is 12v.
Problem 8 Nothing happens after starting the VH controller test.		Check if the driver driver is recognized on the network (Menu Information > Network diagnostics). If it is not found, check power supply as well as cable continuity.
		Check the continuity of the wheel sensor and hydraulic valve cables.
		Check hydraulic installation (if there are no inverted connections, etc.).



Problems	Causes	Solutions
Problem 9 Problems with the autopilot		Check reservoir Oil Level.
		Check for Leaks.
		Check autopilot driver attachment.
		Check Wheel Sensor.
Problem 10 Does not read PITCH values.	Problem on the Driver	Replace equipment.
Problem 11 Does not read ROLL values.	Problem on the Driver,	Replace equipment.